

**RESpace** 

Attorno	pag.98
George	pag.94
Nigora	pag.90
Ri-letto	pag.74
Slim	pag.102
Softly	pag.78
Somnus	pag.84

**LETTI BEDS**

**DIVANI LETTO SOFA BEDS**

Begin	pag.50
Begin XL	pag.60
Facile	pag.64
Joint	pag.46
Logic	pag.42
Mercurio BL	pag.18
Mercurio BS	pag.32
Mercurio Classico	pag.34
Next	pag.12
Quick	pag.68
Spacco	pag.70
Suave	pag.6

**SEDUTE SEATS**

Playspace	pag.142
Q-Bello	pag.152
Ringspace	pag.148



**DIVANI SOFAS**

Elegantia	pag.124
Leonard	pag.116
Motus	pag.132
Planet	pag.108
Roger	pag.136



**MATERASSI MATTRESSES**

Aqua	pag.158
Sand	pag.158
Seasand	pag.159

**GUANCIALI CUSHIONS** pag.161

**DISEGNI TECNICI TECHNICAL DRAWINGS**



**DIVANI LETTO**  
SOFA BEDS





Divano letto dalle forme morbide, una trapunta in piuma lo ricopre completamente sia nella parte del telaio che sulle imbottiture, in abbinamento ad un inserto in poliuretano espanso per un giusto sostegno.

Sofa bed with soft contours; a feather quilt covers the frame and padding and there is a polyurethane foam insert for good support.

Canapé convertible aux formes souples, entièrement recouvert d'un revêtement piqué en plumes, aussi bien au niveau de la structure que du garnissage, et contenant une mousse en polyuréthane expansé pour obtenir une bonne tenue.





## SUAVE

Coniuga perfettamente le funzioni letto e divano. La rete inserita permette di realizzare una seduta bassa che gli conferisce tutte le caratteristiche di comfort di un vero divano, riuscendo a contenere un letto comodo.

Perfectly combines the functions of a bed and a sofa. The mesh fits down to form a low seat with all the comfort of a real sofa while containing a plush bed.

Ce modèle allie les fonctions lit et canapé à la perfection. Son sommier intégré permet d'avoir une assise basse qui lui donne toutes les caractéristiques de confort d'un véritable canapé tout en renfermant un lit confortable.



Non vi accorgete che è un divano letto,  
le proporzioni ottenute sono quelle di un vero divano  
dalla linea elegante e minimal.

It is easy to forget this is a sofa bed as the  
proportions are those of a real sofa in an elegant  
and minimalist style.

Vous ne vous apercevrez même pas que c'est  
un canapé-lit. En effet, ses proportions correspondent  
à celles d'un véritable canapé à la forme élégante  
et minimale.

Composition cm.317x175





## NEXT

Le imbottiture possono essere in poliuretano espanso ad alta densità oppure in abbinamento a morbida piuma, la rete leggera e maneggevole è la più tecnicamente avanzata e permette di realizzare una seduta bassa che gli conferisce tutte le caratteristiche di comfort di un vero divano, riuscendo a contenere un letto comodo.

The padding can be made of high density polyurethane foam or soft feathers, while the light and easy to handle mesh is state-of-the-art and fits down to form a low seat with all the comfort of a real sofa while containing a plush bed.

Le garnissage peut être en polyuréthane expansé haute résilience ou associé à de la plume moelleuse, le sommier léger et souple est à la pointe de la technologie et permet d'avoir une assise basse qui lui donne toutes les caractéristiques de confort d'un véritable canapé tout en renfermant un lit confortable.

NEXT



Sofa bed cm.230x98



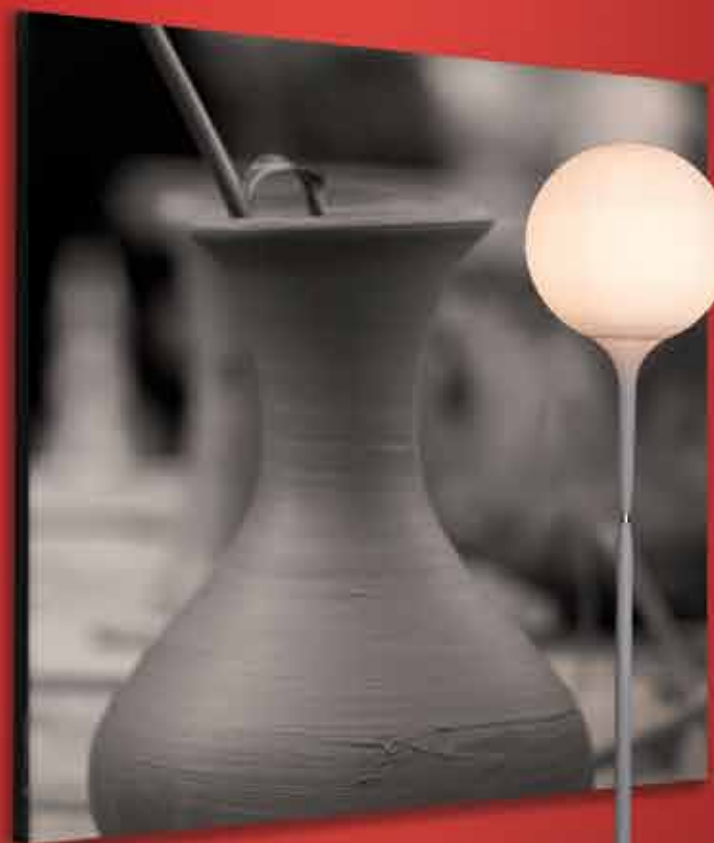

Mercurio BL appartiene alla collezione Mercurio, è fotografato nella versione divano letto 224 cm con imbottiture in poliuretano espanso, rivestite di morbida piuma.

Mercurio BL belongs to the Mercurio collection; the photograph shows a 224 cm version of the sofa bed with polyurethane foam padding covered with soft feathers.

Mercurio BL fait partie de la collection Mercurio. La photo représente la version canapé convertible 224 cm avec garnissage en polyuréthane expansé, recouvert d'un revêtement en plumes moelleuses.

Sofa bed cm.224x95



MERCURIO BL







## MERCURIO BL

Flessibile, versatile e comoda sono le parole che identificano le caratteristiche della collezione, composta da Mercurio BL, Mercurio BS e Mercurio Classico. La versione fotografata riproduce Mercurio BL divano letto, con sedute e schienali in poliuretano espanso.

Flexible, versatile and comfortable are the words that best describe this collection formed of Mercurio BL, Mercurio BS and Mercurio Classico. The version shown in the photograph is the Mercurio BL sofa bed with seat and back in polyurethane foam.

Flexible, polyvalent et confortable, voilà les mots qui caractérisent le mieux la collection composée de Mercurio BL, Mercurio BS et Mercurio Classico. La photo représente la version Mercurio BL canapé convertible, avec assises et dossiers en polyuréthane expansé.

Sofa bed cm.224x95



Ogni elemento della collezione è realizzato nelle versioni divano, divano letto, divano contenitore e composizione con penisola contenitore. I materiali utilizzati nelle imbottiture hanno elevati standard qualitativi.

Every item in the collection is available in the versions: sofa, sofa bed, sofa with storage and composition with chaise storage section. The material used for the padding is of a very high standard of quality.

Tous les éléments de la collection existent dans les versions canapé, canapé convertible, canapé coffre de rangement et composition avec méridienne coffre de rangement. La qualité des matériaux utilisés pour le garnissage est très élevée.



## MERCURIO BL

La penisola contenitore si apre a compasso tramite una maniglia ed è realizzata con un fondo in bilaminato estraibile.

The chaise storage section has a hinged opening with handle and an extractable base made of bilaminate.

La méridienne coffre de rangement possède une ouverture par compas qui se fait au moyen d'une poignée et un fond en bilaminé amovible.

Composition cm.310x175





**MERCURIO BL**  
MERCURIO COLLECTION

Le reti elettrosaldate, inserite in telai di acciaio ad alta resistenza, sono cinghiate nella parte inferiore per un maggior comfort di seduta. Completamente assemblabile attraverso un sistema di baionette.

The electrically welded mesh, situated in frames made of high tensile steel, is strapped at the bottom for sitting in greater comfort. Bayonet system for complete assembly.

Les sommiers électrosoudés, intégrés dans des structures en acier très résistantes, possèdent des sangles sur la partie inférieure, ce qui permet d'avoir une assise plus confortable. Entièrement assemblable grâce à un système de baïonnette.

Composition cm.310x175





Il bracciolo stretto consente di risolvere il problema degli spazi ridotti e dona al divano un aspetto più fresco e giovane, soprattutto nella versione con ruote, che inoltre ne facilita lo spostamento.

The narrow arm rest resolves the problem of limited space and gives the sofa a fresher and younger look, especially in the case of the version with castors which is easy to move.

Grâce à l'accoudoir étroit, les espaces réduits ne sont plus un problème. En outre, il donne un air jeune et moderne au canapé, notamment dans la version sur roulettes qui permet également d'en faciliter le déplacement.

Sofa bed cm.200x95





**MERCURIO CLASSICO**  
MERCURIO COLLECTION



## MERCURIO CLASSICO

Divano con bracciolo dalla forma classica, realizzabile con balza e senza balza, come tutti gli elementi della collezione è prodotto nelle versioni divano, divano letto, divano contenitore e composizione con penisola contenitore.

Le finiture sono l'espressione delle capacità manifatturiere italiane; donano eleganza e ricercatezza al prodotto, ma anche funzionalità, attraverso una sfoderabilità del tessuto semplificata.

Classic-style sofa with arm rest and with or without ledge; like all the items in the collection, it is available in the versions of sofa, sofa bed, sofa with storage and composition with chaise storage section.

The finishing touches are emblematic of Italian manufacture; they add elegance and prestige to the product as well as functionality with easily removable covers.

Canapé muni d'un accoudoir à la forme classique, disponible avec ou sans volant et, comme tous les modèles de la collection, dans les versions canapé, canapé convertible, canapé coffre de rangement et composition avec méridienne coffre de rangement. Les finitions expriment toute la qualité de la fabrication italienne. Elles confèrent une certaine élégance et un certain raffinement au produit, ainsi qu'une certaine fonctionnalité grâce à un déhousseage simplifié.

Composition cm.313x175







## LOGIC

Evoluzione della serie Mercurio di cui possiede le caratteristiche principali è composto da poltrona e divani disponibili nelle versioni letto, contenitore o fissi. Il bracciolo di soli 7 cm consente la realizzazione di elementi di misura ridotta che si adattano ad ogni spazio. Il basamento cromato arricchisce e completa la struttura.

The evolution of the Mercurio series, with the same main features and consisting of an armchair and sofas available in bed, storage unit and fixed versions. The arm rest of just 7 cm permits the creation of smaller items suitable for rooms of all sizes. The chrome-plated base completes the structure in style.

Évolution de la gamme Mercurio dont il possède les principales caractéristiques, ce modèle est composé d'un fauteuil et de canapés disponibles dans les versions convertibles, coffre de rangement ou fixes. L'accoudoir de 7 cm de large seulement permet de réaliser des éléments peu encombrants qui s'adaptent à tous les espaces. La base chromée vient enrichir et compléter la structure.

Sofa bed cm.190x95  
Armchair cm.100x95



Joint è realizzabile nelle versioni divano, divano letto, divano contenitore e composizione con penisola contenitore.

Joint is available in the versions: sofa, sofa bed, sofa with storage and composition with chaise storage section.

Joint existent dans les versions canapé, canapé convertible, canapé coffre de rangement et composition avec méridienne coffre de rangement.



Sofa bed cm.206x95



## JOINT



Caratteristica di Joint è lo snodo nel bracciolo che consente di variare l'estetica del divano e abbina alla funzione di semplice sostegno del braccio quella di appoggio, molto utile nella versione divano letto, perché può fungere da piccolo comodino.

A feature of Joint is the articulated joint in the arm rest for changing the aesthetic effect of the sofa; the joint acts as a simple support for the arm as well as a rest, very useful in the sofa bed version as it can serve as a small bedside table.

La caractéristique de Joint est la rotule située dans l'accoudoir, qui permet de varier l'esthétique du canapé et de faire de cet accoudoir un véritable support pour le bras. Il s'avère très utile dans la version canapé-lit car il peut faire office de petite table de chevet.



## BEGIN

Begin nasce dall'esigenza di avere un divano letto essenziale, con una rete tecnicamente ineccepibile, meno sofisticata, ma robusta e funzionale. Begin è realizzato nelle versioni divano letto, poltrona letto e composizione con penisola contenitore. Le imbottiture sono in poliuretano espanso ad alta densità.

Begin was born of the need for an essential sofa bed with technically exceptional mesh, not overly sophisticated but sturdy and functional. Begin is available in the versions: sofa bed, chair bed and composition with chaise storage section. The padding is made of high density polyurethane foam.

La caractéristique de Joint est la rotule située dans l'accoudoir, qui permet de varier l'esthétique du canapé et de faire de cet accoudoir un véritable support pour le bras. Il s'avère très utile dans la version canapé-lit car il peut faire office de petite table de chevet.

Sofa bed cm.206x95





## BEGIN

Begin poltrona è realizzata con bracciolo da 10 cm per un ingombro contenuto, a differenza delle versioni divano e composizione che hanno il bracciolo da 13 cm, a richiesta è possibile averli entrambi su tutte le versioni.

The Begin armchair has a 10 cm arm rest in the interest of compactness, unlike the sofa and composition versions which have a 13 cm arm rest; it is possible to have both in all versions.

Le fauteuil Begin possède un accoudoir de 10 cm de large, ce qui en limite l'encombrement, contrairement aux versions canapé et composition, qui ont un accoudoir de 13 cm de large. Il est possible d'avoir les deux sur toutes les versions.

Armchair bed cm.110x95



Begin composizione risolve il problema dello spazio per guanciali e coperte, con la penisola contenitore dotata di maniglia per l'apertura a compasso e il fondo in bilaminato.

The Begin composition resolves the problem of space for the cushions and covers, with a chaise storage section with hinged opening, handle and bilaminated base.

Avec la composition Begin, vous saurez toujours où ranger vos oreillers et vos couvertures, grâce à la méridienne coffre de rangement munie d'une poignée pour permettre l'ouverture par compas et d'un fond en bilaminé.

Sofa bed cm.290x175



Struttura in acciaio ad alta resistenza, verniciata a forno con polveri epossidiche, il piano e la seduta sono realizzati con rete elettrosaldata. Il materasso è lungo 190 cm ed è in poliuretano espanso rivestito con leggera imbottitura trapuntata.

The structure is made of high-tensile steel with epoxy powder coating, while the level section and seat are made of electrically welded mesh. The mattress is 190 cm long and made of polyurethane foam with light quilted padding.

Structure en acier très résistante, peinte au four avec des poudres époxy, la surface et l'assise sont composées d'un sommier électrosoudé. Le matelas mesure 190 cm de long et est en polyuréthane expansé recouvert d'un léger garnissage piqué.









## BEGIN XL



Mantiene le caratteristiche della serie Begin, modificato nell'estetica, una struttura più importante con bracciolo 24 cm, per ambienti moderni e spaziosi. Realizzato nella versione divano letto e composizione con penisola contenitore.

It has the same characteristics as the Begin series but with different aesthetics and a bolder structure with 24 cm arm rest for modern, spacious environments. It is available in the versions: sofa bed and composition with chaise storage section.

Ce modèle conserve les caractéristiques de la gamme Begin, seule son esthétique change avec une structure plus importante munie d'un accoudoir de 24 cm, pour des milieux modernes et spacieux. Existe dans les versions canapé convertible et composition avec méridienne coffre de rangement.





## FACILE

Facile è un divano che diventa doppio letto sia in versione singolo che all'occorrenza matrimoniale, molto semplice l'apertura del secondo letto tramite movimento della testata; rete in acciaio con doghe in legno e materassi in poliuretano espanso ad alta densità 75x185 cm, altezza 15 cm rivestiti in cotone.

Facile is a sofa that can be made into a single or double bed, with a second bed that can be opened easily by moving the head; it has steel mesh, wooden slats and high density polyurethane foam mattresses with cotton covering, measuring 75x185 cm and 15 cm in height.

Facile est un canapé qui devient lit double aussi bien dans la version une place que deux places. L'ouverture du deuxième lit est très simple grâce au mouvement de la tête de lit. Sommier en acier avec lattes en bois et matelas en polyuréthane expansé haute résilience 75x185 cm, hauteur 15 cm, revêtement en coton.

Sofa bed cm.200x90



Pouf bed cm.84x94



Pouf letto con apertura semplice, senza necessità di togliere né fodera né cuscino di seduta; con un solo movimento avrete aperto il letto. Materasso unico 80x190 cm. Rete in acciaio elettrosaldato e cinghiata nella parte inferiore, per un maggior comfort di seduta.

Pouf bed that can be opened easily without removing the cover or seat cushions; the bed opens with one simple movement. Single mattress measuring 80x190 cm. Electrically welded steel mesh strapped at the bottom for sitting in greater comfort.

Pouf convertible, ouverture simple qui ne nécessite pas d'ôter la housse du canapé ou les coussins de l'assise. Vous pourrez ouvrir votre lit en un seul mouvement. Matelas unique de 80x190 cm. Sommier en acier électrosoudé et muni de sangles dans la partie inférieure, pour assurer une assise plus confortable.



**SPACCO** design> Renato De Lorenzo 2004

Pouf letto per spazi ridotti; la sua misura contenuta ne permette l'inserimento in ogni ambiente. L'apertura è semplice, il materasso in poliuretano espanso ad alta densità è diviso in tre parti e diventa un letto da 75x195 cm.

Pouf bed for restricted spaces; its compactness makes it suitable for any environment. It is simple to open. The high density polyurethane foam mattress is folded into three parts which, when pulled out, make a bed measuring 75x195 cm.

Pouf convertible pour les espaces réduits. Sa petite taille lui permet de s'adapter à tous les environnements. Ouverture simple, matelas en polyuréthane expansé haute résilience à trois plis qui se transforme en lit de 75x195 cm.



Pouf bed cm.75x65





LETTI  
BEDS

**RI-LETTO** design> Renato De Lorenzo 2011

Tante configurazioni per giocare e avere un letto sempre nuovo, che può diventare con pochi gesti anche divano.

Many configurations with which to play and make a new bed every time; it can also be made into a sofa with just a few simple movements.

D'innombrables configurations pour jouer et toujours avoir un nouveau lit, qui peut se transformer en canapé en quelques gestes.



## RI-LETTO

Un semplice pozzetto sul quale agganciare con snodi in acciaio satinato dei pannelli 1,2,3 o 4, che secondo le tue esigenze possono essere testata o schienale, pediera o bracciolo. Piano letto a doghe, secondo letto con testata in acciaio cromato, due materassi: sopra 195x85 cm, sotto 190x80 cm, sempre altezza 15 cm. Il risultato finale si forma sulle tue scelte puoi aggiungere schienali in poliuretano e guanciali in memory foam per ottenere la configurazione voluta.

A simple section on which panels 1, 2, 3 or 4, the head board, back, foot board and arm rest, can be attached at will with the articulated joints made of brushed steel. Slatted base and head in chrome steel; two mattresses: a top one measuring 195x85 cm and a bottom one measuring 190x80, both 15 cm high. You can arrange the polyurethane backs and memory foam pillows in any way you like.

Chaise longue simple sur laquelle il est possible d'accrocher, au moyen de rotules en acier satiné, des panneaux (1, 2, 3 ou 4) qui peuvent servir de tête de lit, de dossier, de repose-pied ou d'accoudoir. Lit à lattes, tête de lit en acier chromé, deux matelas: dessus 195x85 cm, dessous 190x80 cm, hauteur 15 cm pour les deux modèles. Le résultat final ne dépend que de vous. Vous pouvez ajouter des dossiers en polyuréthane et des oreillers à mémoire de forme pour obtenir la configuration que vous souhaitez.



Bed cm.215x95

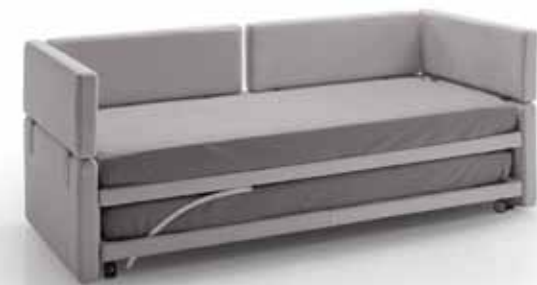





Il letto che anticipa il piacere del sonno con la sua forma morbida e accogliente, data da un'imbottitura in piuma che lo avvolge completamente.

The bed guarantees a pleasurable sleep thanks to its soft and welcoming design with all-enveloping feather padding.

Le lit qui anticipe le plaisir du sommeil grâce à sa forme souple et chaleureuse issue d'un garnissage en plumes qui l'enveloppe totalement.





## SOFTLY

Nasconde anche un ampio contenitore per riporre coperte e lenzuola e vi faciliterà il riassetto del letto tramite il meccanismo a due posizioni che porta il piano della rete ad un'altezza consona. Il vano ha maniglie in cuoio per l'estrazione dei pannelli.

It also has a hidden storage section in which to keep sheets and blankets, and a two-position mechanism for setting the level of the mesh at a suitable height for the bed. The compartment has leather handles for extracting the panels.

Ce modèle renferme également un grand coffre permettant de ranger les couvertures et les draps. Vous pourrez refaire le lit plus facilement grâce au mécanisme à deux positions qui permet d'amener le lit à la bonne hauteur. Le coffre est muni de poignées en cuir pour l'extraction des panneaux.



Un letto, due testate, MAXI h.120 cm e MIDI h.90 cm, il giro letto ha un'imbottitura in poliuretano ad alta densità 75SR che lo enfatizza e gli dona un aspetto importante. In tutte e due le versioni è possibile trapuntare il piano della testata.

A bed, two head boards (MAXI and MIDI, 120 and 90 cm high respectively). The bed frame has 75SR high density polyurethane foam padding that makes it look both bold and impressive. The head board can be quilted in both versions.

Un lit, deux têtes (MAXI: hauteur 120 cm et MIDI: hauteur 90 cm), le garnissage du tour de lit est en polyuréthane haute résilience 75SR, qui l'amplifie et lui donne un air important. Il est possible de piquer le plan de la tête de lit dans les deux versions.

Bed cm.182x220



## SOMNUS MAXI E MIDI

Bed cm.182x220

Letto contenitore per riporre coperte e lenzuola, vi faciliterà il riassetto del letto tramite il meccanismo a due posizioni che porta il piano della rete ad un'altezza consona. Il vano ha maniglie in cuoio per l'estrazione dei pannelli.

The bed has a storage section in which to keep sheets and blankets, and a two-position mechanism for setting the level of the mesh at a suitable height. The compartment has leather handles for extracting the panels.

Lit coffre de rangement permettant de ranger les couvertures et les draps. Vous pourrez refaire le lit plus facilement grâce au mécanisme à deux positions qui permet d'amener le lit à la bonne hauteur. Le coffre est muni de poignées en cuir pour l'extraction des panneaux.



Un letto, due testate, MAXI h.120 cm e MIDI h.90 cm, il giro letto ha un'imbottitura in poliuretano ad alta densità 75SR che lo enfatizza e gli dona un aspetto importante. In tutte e due le versioni è possibile trapuntare il piano della testata.

A bed, two head boards (MAXI and MIDI, 120 and 90 cm high respectively). The bed frame has 75SR high density polyurethane foam padding that makes it look both bold and impressive. The head board can be quilted in both versions.

Un lit, deux têtes (MAXI: hauteur 120 cm et MIDI: hauteur 90 cm), le garnissage du tour de lit est en polyuréthane haute résilience 75SR, qui l'amplifie et lui donne un air important. Il est possible de piquer le plan de la tête de lit dans les deux versions.

Bed cm.182x220





## NIGORA

Equilibrato e raffinato è un letto dalle forme minimal, si presta ad ogni personalizzazione. Il basamento cromato lo impreziosisce e lo completa.

Balanced and elegant, this bed is minimalist in style and suited to all tastes. The chrome base completes the bed and adds a note of elegance.

Équilibré et raffiné, ce lit aux formes minimales, se prête à toutes les personnalisations. La base chromée vient l'enrichir et le compléter.

Bed cm.168x215



## NIGORA



Nasconde anche un ampio contenitore per riporre coperte e lenzuola e vi faciliterà il riassetto del letto tramite il meccanismo a due posizioni che porta il piano della rete ad un'altezza consona. Il vano ha maniglie in cuoio per l'estrazione dei pannelli.

It also has a hidden storage section in which to keep sheets and blankets, and a two-position mechanism for setting the level of the mesh at a suitable height for the bed. The compartment has leather handles for extracting the panels.

Ce modèle renferme également un grand coffre permettant de ranger les couvertures et les draps. Vous pourrez refaire le lit plus facilement grâce au mécanisme à deux positions qui permet d'amener le lit à la bonne hauteur. Le coffre est muni de poignées en cuir pour l'extraction des panneaux.





Letto imbottito per eccellenza con i comodi cuscini sulla testata, personalizzabile attraverso la scelta del rivestimento e di particolari come il piede legno o la ruota (vedi pag. 101), che lo caratterizzano e lo definiscono nella versione desiderata, più classico o più moderno.

A bed superbly padded with comfortable cushions at the head and with a choice of covers and features like wooden feet or castors (see page 101), depending on whether you want a more classic or modern version.

Le lit rembourré par excellence, muni de coussins confortables sur la tête de lit et pouvant être personnalisé en choisissant le revêtement et les différents détails tels que les pieds en bois ou les roulettes (voir page 101), qui le caractérisent ou le définissent dans la version souhaitée, plus classique ou plus moderne.



GEORGE

Bed cm.168x215



Letto dalla forma lineare e misure contenute, adatto a tutte le situazioni dove lo spazio è limitato.  
La ruota lo identifica come prodotto moderno e giovane oltre che semplificarne lo spostamento.

A bed in a compact and linear style, suited to all situations where space is limited.  
The castors make this a modern, young product as well as facilitate movement.

Lit à la forme linéaire et aux dimensions réduites, idéal pour tous les petits espaces.  
Les roulettes en font un produit jeune et moderne et en facilitent le déplacement.



ATTORNO



La ruota ha il freno per il blocco del letto, è possibile utilizzarla per tutti i modelli, esiste nei colori nero+alluminio e arancio+bianco.

The castors have brakes to fix the bed into position; they are available for all the models and are black+aluminium and orange+white in colour.

Les roulettes sont munies d'un frein pour bloquer le lit. Elles peuvent être utilisées sur tous les modèles et existent dans les coloris suivants: noir+aluminium et orange+blanc.

Bed cm.168x209





## SLIM

Slim nasce dall'esigenza di avere un letto semplice con contenitore ad alzata singola, funzionale e robusto, meno prezioso nelle finiture, ma che risponde ad esigenze precise di spazio e contenimento.

Slim was born of the need for a simple bed with single lifting storage section that could be functional and sturdy, less fussy in design but able to meet the precise need for space and compactness.

Slim naît de la nécessité d'avoir un lit commode muni d'un coffre à ouverture simple, fonctionnel et solide, aux finitions moins riches mais qui répond aux besoins précis de place et d'espace.

Bed cm.168x205





**DIVANI**  
SOFAS

Componibile molto flessibile perchè realizzato con moduli di varie misure sia in larghezza che in profondità, abbinabili a formare divani e composizioni ad angolo o con penisola.

Modular and very flexible, with modules varying in width and depth that can be put combined to form sofas and compositions with corner or storage section.

Modèle composable très flexible composé de plusieurs modules de différentes tailles aussi bien en largeur qu'en profondeur, pouvant être associés pour former des canapés et des solutions d'angle ou avec méridienne.









## PLANET

Le imbottiture di seduta possono essere scelte fra poliuretano ad alta densità o piuma con inserto in poliuretano. Schienali e cuscinetti sono in versione piuma "etichetta oro".

The seats can be padded with a choice of either high density polyurethane or feathers with polyurethane insert. Back rests and cushions only in "gold label" feather version.

Le garnissage de l'assise est au choix entre polyuréthane haute résilience ou plumes avec mousse de polyuréthane. Dossiers et coussins en plumes certifiées "étiquette d'or".

Sofa cm.250x97



Espressione dell'esperienza progettuale e manifatturiera italiana, elegante e proporzionato, consente una componibilità con estrema libertà funzionale.

An expression of true Italian design and manufacture, elegant and well proportioned, it can be arranged with absolute functional freedom.

Expression de l'expérience italienne en matière de conception et de production, élégant et proportionné, ce modèle composable permet d'avoir une très grande liberté fonctionnelle.

Sofa cm.300x330



## LEONARD

I moduli sono completati con un basamento cromato, le imbottiture della seduta sono in poliuretano abbinato a piuma, gli schienali sono in piuma, sempre certificata.

The modules are completed with a chrome base, the seat padding is made of polyurethane and feathers and the back rests are made of feathers; it is all certified.

La base chromée vient compléter les modules, le garnissage de l'assise est en polyuréthane et plumes, les dossiers sont en plumes, toujours certifiées.













Armchair cm.85x75



## ELEGANTIA

Divani e moduli componibili di armoniose proporzioni danno vita a molteplici soluzioni, realizzato in due profondità 100 cm e 120 cm, è completato dalla versione "poltroncina" di 75 cm.

The sofas and modules are of gracious proportions and can be arranged in various ways, with a depth of 100 and 120 cm; there is also a 75 cm "small armchair" version.

Canapés et modules composables aux proportions harmonieuses qui permettent d'obtenir de nombreuses solutions, existent dans deux profondeurs: 100 cm et 120 cm. La gamme est complétée par la version "petit fauteuil" de 75 cm.

Sofa cm.300x100



## ELEGANTIA

Imbottiture di seduta in poliuretano espanso e memofill, schienali con cuscini in piumino che si possono spostare a vostra discrezione, sostenuti da lunette poggiatesta che rendono unico il comfort di questo divano.

Seat padding in polyurethane and memofill, back rests with feather cushions that can be arranged at will and head rests to make this sofa uniquely comfortable.

Garnissage de l'assise en polyuréthane expansé et memofill, dossiers et coussins en plumes d'oie pouvant être déplacés à votre gré et soutenus par des appuie-tête qui rendent le confort de ce canapé unique.





Divano dalle molteplici configurazioni, dotato di un meccanismo in acciaio con pistone idraulico e cricchetti posizionabili. Potete scegliere se utilizzarlo come un grande pouf, divano con o senza braccioli e chaise longue. Vera libertà di movimento.

A sofa of many configurations, featuring a steel mechanism with hydraulic piston and adjustable ratchet handles. You can choose whether to use it as a large pouf or sofa with or without arm rests, or as a chaise longue. Complete freedom of movement.

Canapé aux multiples configurations, équipé d'un mécanisme en acier avec piston hydraulique et cliquets positionnables. Vous pouvez choisir de l'utiliser comme grand pouf, comme canapé avec ou sans accoudoirs et comme chaise longue. Une véritable liberté de mouvement.

Sofa cm.200x100





Armchair cm.100x100







Moderno per eccellenza, dalle forme pure, realizzato nella versione divano e moduli componibili. Imbottiture della seduta in poliuretano espanso e schienali in piuma.

Modern par excellence, of pure design, in sofa and modular version. Seat padding made of polyurethane foam and back rests with feather padding.

Moderne par excellence, formes pures. Existe dans la version canapé et modules composables. Garnissage de l'assise en polyuréthane expansé et dossiers en plumes.



**SEDUTE**  
SEATS





PLAYSPACE



## PLAYSPACE

Leggero e plasmabile, lo modellate sul vostro corpo trasformandolo in chaise longue, divano, poltrona con o senza braccioli, e in qualsiasi forma confortevole desideriate.

È adatto per spazi interni ed esterni.

Composto da una sacca interna contenente microsferine in polistirene miste a espanso a memoria di forma, Playspace è interamente sfoderabile.

È ricaricabile: nell'uso prolungato e intensivo potrebbe verificarsi un decadimento dell'originario volume della sacca interna. Respace fornisce le ricariche da integrare con l'imbottitura già presente all'interno.

Materiali e produzione interamente Made in Italy.

Light and pliable, you can adapt it to suit your body by turning it into a chaise longue, sofa, an armchair with or without arm rests, and into any comfortable form you desire. It is suitable for use either inside or outside. Playspace consists of an internal bag containing polystyrene and memory foam micro-balls with an easy-to-remove cover.

It is refillable: the original volume of the internal bag can decrease the longer and more intensively it is used. Respace provides refills which can be added to the padding inside. Materials and manufacture all in Italy.

Léger et malléable, vous pouvez le modeler sur votre corps en le transformant en chaise longue, en canapé, en fauteuil avec ou sans accoudoirs et dans n'importe quelle autre forme confortable.

Idéal à l'intérieur comme à l'extérieur, le modèle Playspace est composé d'une poche interne contenant des microsphères en polystyrène et expansé à mémoire de forme et est entièrement déhoussable.

Il est rechargeable. En effet, à long terme, après une usage intensif, il se peut que le volume original de la poche interne diminue. Respace fournit les recharges déjà munies du garnissage.

Tous les matériaux et la production sont Made in Italy.





## RINGSPACE

Spazio rotondo per sedersi in 1, 2 o anche 3, da usare come appoggio o come gioco, simpatico oggetto adatto ad ogni ambiente. Imbottitura protetta da una sacca interna contenente microsfere di polistirene. Interamente sfoderabile.

A round space for seating 1, 2 or even 3 people, to be used as a support or for play; a fun object suited to all environments. Padding protected by an internal bag containing polystyrene micro-balls. Removable cover.

Modèle rond pour s'asseoir seul, à deux ou à trois, à utiliser comme support ou pour s'amuser. Objet sympathique idéal pour tous les environnements. Garnissage protégé par une poche interne contenant des microsphères en polystyrène. Entièrement déhoussable.

Seat cm.ø90





Seat cm.50x50

Pouf a memoria di forma, comodo e pratico sia per abitazioni che per locali pubblici e spa.

A pouf made of memory foam comfortable and practical for the home, communal areas and spas.

Pouf à mémoire de forme, confortable et pratique aussi bien pour les habitations que pour les lieux publics et les spas.





**MATERASSI E GUANCIALI**  
MATTRESSES AND CUSHIONS



## BENESSERE, RIPOSO, COMFORT, NATURA

WELLNESS, RELAXATION, COMFORT, NATURE

BIEN-ÊTRE, REPOS, CONFORT, NATURE



### AQUA



Creato per dare il massimo comfort al tuo riposo, AQUA esalta l'elasticità del poliuretano ad alta densità, materiale a cellula aperta tra i più evoluti. Lo standard qualitativo superiore determina *sag factor*, fattore di adattamento alla compressione, eccezionale; la morbidezza superficiale unita alla capacità di distribuire e sostenere il peso del corpo garantiscono un vero "sonno ristoratore".

Designed to give maximum comfort to your rest AQUA enhances the elasticity of polyurethane foam, open cell material, the most advanced. The standard of quality higher *sag factor*, determining factor in adaptation to compression, exceptional, and the surface smoothness combined the capacity to distribute and support the weight of the body provide a real "sleep".

Conçu pour donner le maximum de confort à votre repos, AQUA exalte l'élasticité de polyuréthane expansé, l'une des matières à cellules ouvertes les plus évoluées. Son standard de qualité supérieur permet d'obtenir un *sag factor* ou facteur de compression exceptionnel. La souplesse de la surface et la capacité de répartir et de soutenir le poids du corps assurent un véritable "sommeil réparateur".

#### Caratteristiche:

Altezza totale materasso 20 cm.  
 Comfort ed elasticità  
 Morbidezza  
 Traspirabilità  
 Resistenza nel tempo  
 Materiali riciclabili eco-compatibili certificati e garantiti  
 Foderina in cotone 100%  
 Non contiene prodotti nocivi, CFC e solventi clorurati  
 Disponibile anche su misura  
 10 Anni di garanzia

#### Features:

Total height of mattress 20 cm  
 Comfort ed elasticity  
 Softness  
 Breathability  
 Durability  
 Certified and guaranteed eco-compatible recyclable materials  
 Cover in 100% cotton  
 Does not contain toxic products, CFCs or chlorinated solvents  
 Also available made to measure  
 10 year warranty

#### Caractéristiques:

Hauteur totale matelas 20 cm  
 Confort et élasticité  
 Souplesse  
 Respirabilité  
 Résistance dans le temps  
 Matériaux recyclables éco-compatibles certifiés et garantis  
 Housse 100% coton  
 Ne contient pas de produits nocifs, de CFC et de solvants chlorés  
 Disponible sur mesure également  
 Garanti 10 ans

### SAND



Materasso in poliuretano ad elevato sostegno, fodera con zip totalmente removibile. Nato per soddisfare le esigenze di chi richiede maggiore rigidità, SAND assicura alte prestazioni e comfort, garantendo il giusto supporto e mantenendo forma e sostegno nel tempo. Materiali eco-compatibili certificati e garantiti, non contiene prodotti nocivi, CFC e solventi clorurati.

Polyurethane foam high mattress support, fully removable cover with zip. Born to meet the needs of those who require greater rigidity, SAND ensures high performance and comfort, insuring the right support and maintain shape and support over time. Environmentally friendly material are guaranteed and safe, contains no harmful substances, CFC and chlorinated solvents.

Matelas de polyuréthane expansé haute tenue, housse munie d'une fermeture éclair et entièrement amovible. Conçu pour satisfaire les exigences des personnes ayant besoin de plus de fermeté, SAND fournit de hautes performances et un grand confort tout en assurant un soutien adéquat et en conservant sa forme et sa tenue dans le temps. Matériaux éco-compatibles certifiés et garantis, ne contient pas de produits nocifs, de CFC et de solvants chlorés.

#### Caratteristiche:

Altezza totale materasso 19 cm  
 Ortopedico  
 Sostegno elevato  
 Rigidità  
 Indeformabilità  
 Resistenza nel tempo  
 Traspirabilità  
 Materiali riciclabili eco-compatibili certificati e garantiti  
 Foderina in cotone 100%  
 Non contiene prodotti nocivi, CFC e solventi clorurati  
 Disponibile anche su misura  
 10 Anni di garanzia

#### Features:

Total height of mattress 19 cm  
 Orthopaedic  
 Excellent support  
 Firmness  
 Non-deformability  
 Durability  
 Breathability  
 Certified and guaranteed eco-compatible recyclable materials  
 Cover in 100% cotton  
 Does not contain toxic products, CFCs or chlorinated solvents  
 Also available made to measure  
 10 year warranty

#### Caractéristiques:

Hauteur totale matelas 19 cm  
 Orthopédique  
 Haute tenue  
 Fermeté  
 Indéformabilité  
 Résistance dans le temps  
 Respirabilité  
 Matériaux recyclables éco-compatibles certifiés et garantis  
 Housse 100% coton  
 Ne contient pas de produits nocifs, de CFC et de solvants chlorés  
 Disponible sur mesure également  
 Garanti 10 ans

## SEASAND

Ognuno di noi ha peso, calore e proporzioni uniche e comunque variabili nel tempo: adagiandosi su SEASAND il nostro corpo ne imprime la forma. Si crea così un'impronta "unica" conseguente alla forma, al calore e al peso in quel momento esercitato. Una volta alzati, il materiale ritorna nella sua forma originaria pronto a ricevere un'altra impronta. Le schiume viscoelastiche sono materiali termosensibili, che grazie al calore si automodellano distribuendo il peso su tutta la superficie interessata e riducendo la pressione esercitata sul corpo con enormi benefici: la pressione che il peso del corpo esercita durante il decubito su un supporto troppo rigido può infatti danneggiare i tessuti e la circolazione ematica e linfatica del sottocute. Il riposo in posizione naturale con il corpo libero da tensioni e compressioni è possibile grazie alle proprietà del materasso SEASAND: le speciali curve, disegnate per meglio seguire e sostenere le parti del corpo, permettono di scaricare l'energia e il peso delle zone maggiormente sollecitate: spalle, zona lombare e bacino.

Each human body has its own characteristic weight, heat and proportions which can also change over time, and the human body leaves its own impression when lying down on SEASAND. The shape, heat and weight of your body leave a "unique" impression when you are recumbent. When you stand up, the material is restored to its original form, ready to receive another impression. Viscoelastic foam is heat-sensitive material which adapts with heat to distribute the weight all over the surface on which you lie, reducing the pressure exercised on your body with great benefits: the pressure that the weight of your body exercises when you are lying on too firm a surface can harm the tissue and circulation in the subcutaneous hemic and lymphatic system. Lying in a natural position with your body free of stress and pressure is made possible by the properties of the SEASAND mattress: it is specially designed to best follow and support the various parts of your body and thereby help release the energy and weight in the areas most prone to stress: the shoulders, the lumbar region and the pelvis.

Nous avons tous un poids, une chaleur et des proportions uniques et variables dans le temps. En vous allongeant sur SEASAND, votre corps y laisse sa trace. Vous obtenez ainsi une empreinte "unique" qui correspond à la forme, à la chaleur et au poids exercés lorsque vous allongez. Après vous être levé, la matière reprend sa forme originale, prête à recevoir une autre empreinte. Les mousses viscoélastiques sont des matières termosensibles, qui "s'automodèlent" grâce à la chaleur en répartissant le poids sur toute la surface concernée et en réduisant la pression exercée sur le corps, ce qui permet d'obtenir d'énormes bienfaits. En effet, la pression exercée par le poids du corps lorsqu'il est allongé sur un support trop ferme peut endommager les tissus et la circulation hématique et lymphatique des tissus sous-cutanés. Vous pouvez désormais vous reposer dans une position naturelle sans que votre corps soit tendu ou comprimé grâce aux propriétés du matelas SEASAND. En effet, ses courbes spécialement conçues pour mieux épouser et soutenir les parties du corps permettent de décharger l'énergie et le poids des zones les plus sollicitées: les épaules, la zone lombaire et le bassin.



PRESSIONE SPALLE  
 Pressure on the shoulders  
 Pression epaules

PRESSIONE LOMBARE  
 Pressure on the lumbar region  
 Pression lombaire

PRESSIONE BACINO  
 Pressure on the pelvis  
 Pression bassin

#### Caratteristiche:

Strato superiore in schiuma viscoelastica a ritorno lento  
 Strato inferiore in poliuretano  
 Altezza totale materasso 23 cm  
 Ergonomia  
 Ortopedico  
 Igiene  
 Traspirabilità  
 Non genera allergie  
 Antiacaro  
 Materiali riciclabili eco-compatibili certificati e garantiti  
 Incastrati e assemblaggi privi di collante  
 Foderina in cotone 100%  
 Non contiene prodotti nocivi, CFC e solventi clorurati  
 Disponibile anche su misura  
 10 Anni di garanzia

#### Features:

Top layer of slow-return viscoelastic foam  
 Bottom layer of polyurethane foam  
 Total height of mattress 23 cm  
 Ergonomic  
 Orthopaedic  
 Hygiene  
 Breathability  
 Non-allergic  
 Anti-mite  
 Certified and guaranteed eco-compatible recyclable materials  
 Adhesive-free installation and assembly  
 Cover in 100% cotton  
 Does not contain toxic products, CFCs or chlorinated solvents  
 Also available made to measure  
 10 year warranty

#### Caractéristiques:

Couche supérieure en mousse viscoélastique à retour lent  
 Couche inférieure en polyuréthane expansé  
 Hauteur totale matelas 23 cm  
 Ergonomie  
 Orthopédique  
 Hygiène  
 Respirabilité  
 Anallergique  
 Anti-acariens  
 Matériaux recyclables éco-compatibles certifiés et garantis  
 Emboîtements et assemblages sans adhésif  
 Housse 100 % coton  
 Ne contient pas de produits nocifs, de CFC et de solvants chlorés  
 Disponible sur mesure également  
 Garanti 10 ans

## NATURA



Fodera per materassi in tessuto naturale per un comfort totale del riposo: la freschezza del lino, la carezza della seta, la morbidezza del cachemire.

Il tessuto è caratterizzato da particolari proprietà che determinano la termoregolazione corporea. Il corpo emette varie sostanze insieme all'acqua attraverso la traspirazione; il tessuto mantiene la temperatura del corpo costante grazie alla sua capacità di rimanere asciutto rilasciando o assorbendo l'umidità.

Il benefico effetto antistress che si ottiene con questa fodera è determinato proprio dalla possibilità data al corpo di poter autoregolare la produzione di calore.

Grazie alle sue proprietà è minimo il rilascio di odori. La fodera coprimaterasso NATURA è eco-compatibile: nasce dall'utilizzo di prodotti naturali quali la fibra di legno da potatura, quindi senza l'abbattimento di alberi. Piccole rotondità della fibra donano un particolare effetto di morbidezza al tessuto. Lato invernale trapuntatura in lana e lato estivo trapuntatura in cotone. Qualità e resistenza nel tempo garantite. Disponibile anche su misura. Fodera NATURA con maniglie, apribile perimetralmente. Cerniere e cuciture di ottima qualità e resistenti nel tempo. Utilizzabile per tutti i tipi di materasso. Lavabile a secco.

A mattress cover made of natural fabric for total comfort and relaxation: the freshness of linen, the smoothness of silk and the softness of cashmere.

The particular properties of the fabric assist the self-regulation of body heat. The body releases various substances in water during transpiration; the fabric keeps the temperature of the body constant because it can remain dry by releasing or absorbing humidity. This cover has a beneficial anti-stress effect, allowing the body to self-regulate the production of heat. Thanks to its properties, little odour is released. The NATURA mattress cover is eco-compatible: it is made with natural products like wood fibre from pruned matter, without the felling of trees. The small round shapes of the fibre make the fabric particularly soft. There is woollen quilt on the winter side and cotton quilt on the summer side. Guaranteed quality and durability. Also available made to measure. NATURA cover with handles, opened at the sides. High quality and durable zip fasteners and stitching. Suitable for all types of mattress. Dry washable.

Housse de matelas en tissu naturel pour un repos placé sous le signe du confort total, grâce à la fraîcheur du lin, à la caresse de la soie et au moelleux du cachemire.

Le tissu possède des propriétés singulières qui déterminent la thermorégulation corporelle. Outre l'eau, le corps émet plusieurs substances à travers la sueur.

Le tissu permet de maintenir la température du corps constante grâce à sa capacité de rester sec en relâchant ou en absorbant de l'humidité. L'effet antistress bienfaisant obtenu grâce à cette housse dérive justement de la possibilité que le corps a d'autoréguler la production de chaleur. Ses propriétés permettent de réduire au minimum l'émission d'odeurs.

La housse de matelas NATURA est éco-compatible. En effet, elle est conçue à partir de produits naturels tels que la fibre de bois de taille, ce qui exclut l'abattage d'arbres.

Grâce aux petites rondeurs de la fibre, le tissu est tout particulièrement moelleux. Laine piquée pour la face hiver et coton piqué pour la face été. Qualité et résistance dans le temps assurées. Disponible sur mesure également. Housse NATURA avec poignées et ouverture totale. Fermetures éclair et coutures d'excellente qualité et durables.

Peut être utilisée sur tous les types de matelas. Lavage à sec.



## ONDA

Fodera per materassi resistente e funzionale, comoda e pratica. Grazie alla cerniera perimetrale che consente di sfoderare facilmente il materasso e al tessuto resistente lavabile ad acqua, è la soluzione migliore per sostituire il vecchio coprimaterasso. Le trapuntature sono realizzate con fibre anallergiche. Qualità e resistenza nel tempo garantite.

Disponibile anche su misura. Cerniere e cuciture di ottima qualità e resistenti nel tempo. Utilizzabile per tutti i tipi di materasso.

Fodera ONDA con maniglie, apribile perimetralmente.

A resistant and functional, comfortable and practical mattress cover. The zip fastener around the side, which allows you to remove the cover easily, and the washable in water, fabric make this the best alternative to the old mattress cover. The quilting is made with non-allergenic fibres. Guaranteed quality and durability. Also available made to measure.

High quality and durable zip fasteners and stitching. Suitable for all types of mattress. ONDA cover with handles, opened at the sides.

Housse de matelas résistante et fonctionnelle, confortable et pratique. Grâce à la fermeture éclair couvrant tout le périmètre, qui permet de déhousser facilement le matelas, et au tissu résistant lavable en eau, ONDA est ce qu'il y a de mieux pour remplacer votre vieille housse de matelas. Les piquages sont réalisés au moyen de fibres anallergiques.

Qualité et résistance dans le temps assurées. Disponible sur mesure également. Fermetures éclair et coutures d'excellente qualité et durables.

Peut être utilisée sur tous les types de matelas. Housse ONDA avec poignées et ouverture totale.

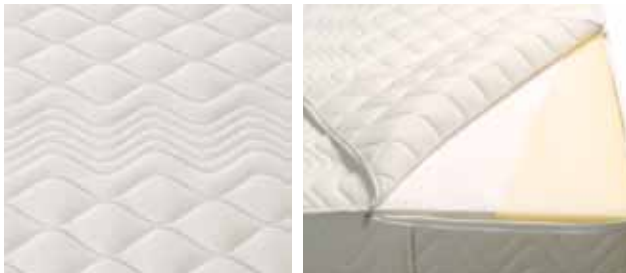

## MEMO COMFORT

Materiale viscoelastico con fori su ambo i lati, fodera in cotone.

Viscoelastic material with perforationas on both size and a cotton cover.

Matière viscoélastique munie d'orifices sur les deux côtés. Housse en coton.



## MEMO COMFORT ALOE

Materiale viscoelastico con fori su ambo i lati, arricchito con aloe, fodera in cotone. Questo prodotto unisce alle eccezionali caratteristiche di comfort del viscoelastico anche le numerose proprietà dell'aloè, soprattutto quelle batteriostatiche e fungicide.

Viscoelastic material with perforationas on both sides, enriched with "aloe vera", cotton cover. This product combines the exceptional comfort of viscoelasticity with the many benefits of "aloe vera", especially its the bacteriostatic and fungicidal properties.

Matière viscoélastique munie d'orifices sur les deux côtés, enrichie d'aloès. Housse en coton. Ce produit allie les exceptionnelles caractéristiques de confort de la matière viscoélastique aux nombreuses propriétés de l'aloès, notamment les propriétés bactériostatiques et fongicides.



## MEMO ERGONOMIC

Materiale viscoelastico con fori su ambo i lati, fodera in cotone, la sua forma ergonomica aiuta le persone con problemi di cervicale donando un buon supporto per la testa.

Viscoelastic material with perforationas on both size and a cotton cover. The ergonomic design provides firm support to those suffering from neck-pain.

Matière viscoélastique munie d'orifices sur les deux côtés. Housse en coton. Sa forme ergonomique aide les personnes souffrant des cervicales en offrant un bon soutien pour la tête.



## MEMO ERGONOMIC ALOE

Materiale viscoelastico con fori su ambo i lati, fodera in cotone, la sua forma ergonomica aiuta le persone con problemi di cervicale donando un buon supporto per la testa. Questo prodotto unisce alle eccezionali caratteristiche di comfort del viscoelastico anche le numerose proprietà dell'aloè, soprattutto quelle batteriostatiche e fungicide.

Viscoelastic material with perforationas on both sides, enriched with "aloe vera", cotton cover. The ergonomic design provides firm support to those suffering from neck-pain. This product combines the exceptional comfort of viscoelasticity with the many benefits of "aloe vera", especially its the bacteriostatic and fungicidal properties.

Matière viscoélastique munie d'orifices sur les deux côtés. Housse en coton. Sa forme ergonomique aide les personnes souffrant des cervicales en offrant un bon soutien pour la tête. Ce produit allie les exceptionnelles caractéristiques de confort de la matière viscoélastique aux nombreuses propriétés de l'aloès, notamment les propriétés bactériostatiques et fongicides.



## SOLO SOFT

Prodotto innovativo di ultima generazione, indeformabile, elastico, morbido. A base di fibre di poliestere può essere riciclato. Comfort straordinario, eccezionale resistenza alla pressione, ritrova poi la sua forma originaria senza deformazioni.

A state-of-the-art, innovative product which is flexible, soft, and always holds shape. It is made of polyester fibres and can be recycled. It provides extraordinary comfort, as excellent resistance to pressure and always reverts back to its original shape without deforming.

Produit innovant de dernière génération, indéformable, élastique et moelleux. A base de fibres de polyester. Peut être recyclé. Confort extraordinaire, exceptionnelle résistance à la pression. Il retrouve sa forme originale sans subir de déformations.



## FODERA SILVER

A tutti i nostri guanciali può essere abbinata la fodera silver: innovativo tessuto tecnico che prevede la dispersione di microfibre di argento nella trama del cotone. La sua particolare lavorazione ne fa un tessuto antistatico, antistress, ad elevato potere antielettrosmog, andando ad eliminare i campi magnetici prodotti dagli elettrodomestici presenti nelle vicinanze. Caratteristica peculiare di questo tessuto è, inoltre, l'elevata capacità antiacaro e anallergica data appunto dalla presenza dell'argento.

Our silver pillow-case fits all our pillows. It is made with an innovative technical fabric containing silver micro-fibres within the cotton weave. It is an antistatic and anti-stress product with unique properties which reduces the effects of electro-smog, helping to protect you and your family from the magnetic fields created by nearby household appliances while you sleep. Thanks to the presence of silver in the material this new fabric is also mite-resistant and hypoallergenic.

La housse Silver peut être utilisée sur tous nos oreillers. Son tissu technique innovant prévoit la dispersion de microfibras d'argent dans la trame du coton. Sa fabrication particulière en fait un tissu antistatique, antistress et doté d'un grand pouvoir anti-électrosmog. En effet, il élimine les champs magnétiques produits par les appareils électroménagers présents à proximité. En outre, ce tissu se distingue de par sa grande capacité anti-acariens et anallergique dérivant justement de la présence d'argent.



## VIAGGIO

Materiale viscoelastico con fodera in cotone. Può essere utilizzato anche come cuscinetto aggiuntivo nei divani.

Viscoelastic material with cotton pillowcase. It may also be used as an additional cushion for sofas.

Matière viscoélastique munie d'une housse en coton. Peut également être utilisée comme coussin additionnel sur les canapés.



## DIVANI LETTO - SOFA BEDS - CANAPÉS-LITS

### BEGIN design> Renato De Lorenzo 2010



Struttura in acciaio ad alta resistenza, verniciata a forno con polveri epossidiche, il piano e la seduta sono realizzati con rete elettrosaldata. Parti schienale e braccioli in legno massello e multistrato. Il materasso in poliuretano espanso ad alta densità è rivestito con leggera imbottitura trapuntata, misure disponibili: 72x190 – 140x190 – 160x190. Imbottiture in poliuretano ad alta densità.

Structure made of high-tensile steel with epoxy powder coating, base section and seat made of electrically welded mesh. Backrest and armrest sections in solid and multilayer wood. The high density polyurethane foam mattress has a lightly quilted cover and is available in sizes: 72x190 – 140x190 – 160x190. High density polyurethane foam padding.

Structure en acier très résistante, peinte au four avec des poudres époxy, la surface et l'assise sont composées d'un sommier électrosoudé. Dossier et accoudoirs en bois massif et stratifié. Le matelas en polyuréthane expansé haute résilience est recouvert d'un léger garnissage piqué. Dimensions disponibles: 72x190 – 140x190 – 160x190. Garnissage en polyuréthane haute résilience.

Pag.50-51:  
Divano 3 posti 206 cm.  
3 Seater sofa 206 cm.

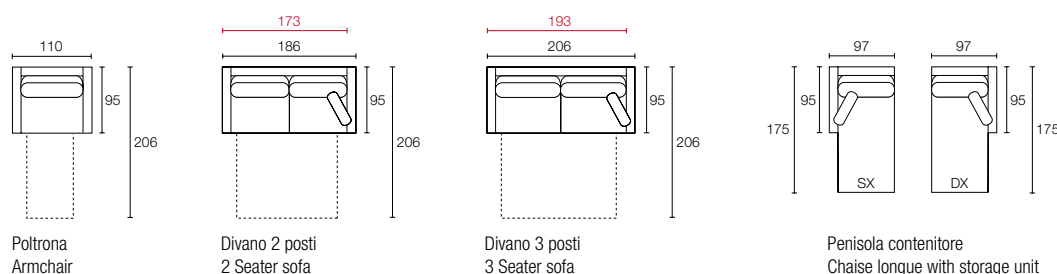

### BEGIN XL design> Renato De Lorenzo 2010



Struttura in acciaio ad alta resistenza, verniciata a forno con polveri epossidiche, il piano e la seduta sono realizzati con rete elettrosaldata. Parti schienale e braccioli in legno massello e multistrato. Il materasso in poliuretano espanso ad alta densità è rivestito con leggera imbottitura trapuntata, misure disponibili: 72x190 – 140x190 – 160x190. Imbottiture in poliuretano ad alta densità.

Structure made of high-tensile steel with epoxy powder coating, base section and seat made of electrically welded mesh. Backrest and armrest sections in solid and multilayer wood. The high density polyurethane foam mattress has a lightly quilted cover and is available in sizes: 72x190 – 140x190 – 160x190. High density polyurethane foam padding.

Structure en acier très résistante, peinte au four avec des poudres époxy, la surface et l'assise sont composées d'un sommier électrosoudé. Dossier et accoudoirs en bois massif et stratifié. Le matelas en polyuréthane expansé haute résilience est recouvert d'un léger garnissage piqué. Dimensions disponibles: 72x190 – 140x190 – 160x190. Garnissage en polyuréthane haute résilience.

Pag.60-61:  
Divano 3 posti 224 cm.  
3 Seater sofa 224 cm.

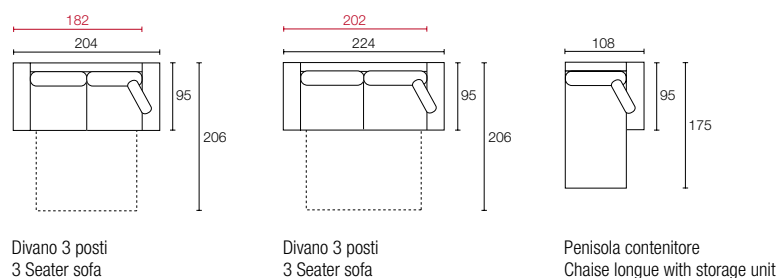

## DIVANI LETTO - SOFA BEDS - CANAPÉS-LITS

### FACILE design> Renato De Lorenzo 2004



Telaio in legno massello e multistrato. Reti in acciaio con doghe in legno. Materassi in poliuretano espanso ad alta densità rivestiti in cotone. Imbottiture degli schienali in poliuretano ad alta densità.

Solid and multilayer wood frame. Steel base with wooden slats. High density polyurethane foam mattresses with cotton cover. High density polyurethane foam backrest padding.

Structure en bois massif et stratifié. Sommier en acier avec lattes en bois. Matelas en polyuréthane expansé haute résilience recouverts de coton. Garnissage des dossiers en polyuréthane haute résilience.

Pag.64-65:  
Divano 3 posti 200 cm.  
3 Seater sofa 200 cm.

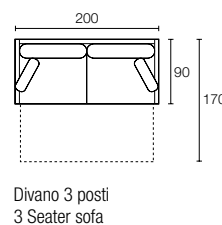

### JOINT design> Renato De Lorenzo 2011



Le reti elettrosaldate, inserite in telai di acciaio ad alta resistenza, con cinghie sulla seduta per un maggior comfort, verniciate con polveri epossidiche, sono certificate CATAS. Parti schienale e braccioli in legno massello e multistrato. Completamente assemblabile attraverso un sistema di baionette. Snodo in acciaio nel bracciolo. Il materasso in poliuretano espanso può essere scelto nella densità, più sostenuto o più elastico, con fodera standard in cotone trapuntato o con tessuto silver dalle caratteristiche antibatteriche, sempre completamente sfoderabili, misure: 100x200 – 140x200 – 160x200. Penisola contenitore con apertura frontale tramite molle a gas Stabilus. Imbottiture in poliuretano ad alta densità oppure poliuretano abbinato a piuma certificata "Assopioma".

The electrically welded bed base, in a high resistance steel frame, with seat strap for better comfort, and epoxy powder coating, is CATAS certified. Backrest and armrest sections in solid and multilayer wood. Bayonet system for complete assembly. Steel articulated joint in the armrest. The level of density of the polyurethane foam mattress may be selected by the customer, firmer or softer, with standard padded cotton cover or antibacterial silver material cover, always removable; sizes: 100x200 – 140x200 – 160x200. Stabilus gas spring front opening storage section. High density polyurethane foam padding, or polyurethane combined with "Assopioma" certified feather.

Les sommiers électrosoudés sont intégrés dans des structures en acier très résistantes, munis de sangles au niveau de l'assise pour plus de confort, peints avec des poudres époxy et certifiés CATAS. Dossier et accoudoirs en bois massif et stratifié. Entièrement assemblable grâce à un système de baionnette. Rotule en acier dans l'accoudoir. Vous pouvez choisir un matelas en polyuréthane expansé plus ferme ou plus élastique, avec une housse standard en coton piqué ou un tissu silver antibactérien, le tout entièrement déhoussable. Dimensions: 100x200 – 140x200 – 160x200. Méridienne coffre de rangement avec ouverture à l'avant par ressorts à gaz Stabilus. Garnissage en polyuréthane haute résilience ou mélange de polyuréthane et plumes certifiées "Assopioma".

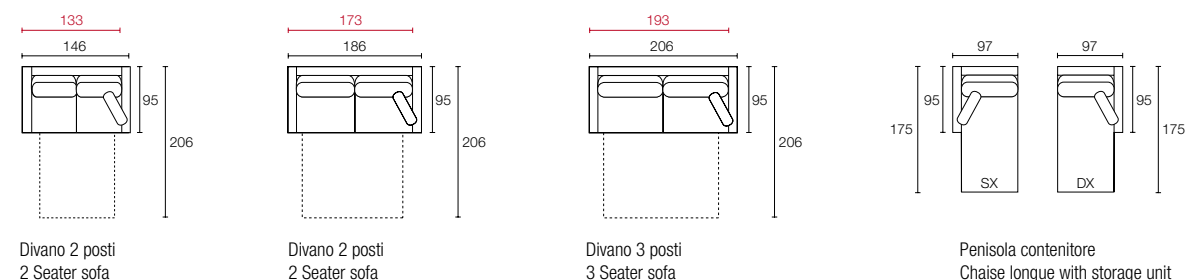

## DIVANI LETTO - SOFA BEDS - CANAPÉS-LITS

### LOGIC design> Renato De Lorenzo 2010



Pag.42-43:  
Poltrona 100 cm.  
Armchair 100 cm.

Le reti elettrosaldate, inserite in telai di acciaio ad alta resistenza, con cinghie sulla seduta per un maggior comfort, verniciate con polveri epossidiche, sono certificate CATAS. Parti schienale e braccioli in legno massello o multistrato. Completamente assemblabile attraverso un sistema di baionette. Il materasso in poliuretano espanso può essere scelto nella densità, più sostenuto o più elastico, con fodera standard in cotone trapuntato o con tessuto silver dalle caratteristiche antibatteriche, sempre completamente sfoderabili, misure: 70x200 – 100x200 – 140x200 – 160x200. Imbottiture in poliuretano ad alta densità oppure poliuretano abbinato a piuma certificata "Assopiuma". Piede con basamento legno finitura cromo.

The electrically welded bed base, in a high resistance steel frame, with seat strap for better comfort, and epoxy powder coating, is CATAS certified. Backrest and armrest sections in solid and multilayer wood. Bayonet system for complete assembly. The level of density of the polyurethane foam mattress may be selected by the customer, firmer or softer, with standard padded cotton cover or antibacterial silver material cover, always removable; sizes: 70x200 – 100x200 – 140x200 – 160x200. High density polyurethane foam padding, or polyurethane combined with "Assopiuma" certified feather. Foot with chrome finish wooden base.

Les sommiers électrosoudés sont intégrés dans des structures en acier très résistantes, munis de sangles au niveau de l'assise pour plus de confort, peints avec des poudres époxy et certifiés CATAS. Dossier et accoudoirs en bois massif et stratifié. Entièrement assemblable grâce à un système de baïonnette. Vous pouvez choisir un matelas en polyuréthane expansé plus ferme ou plus élastique, avec une housse standard en coton piqué ou un tissu silver antibactérien, le tout entièrement déhoussable. Dimensions: 70x200 – 100x200 – 140x200 – 160x200. Garnissage en polyuréthane haute résilience ou mélange de polyuréthane et plumes certifiées "Assopiuma". Pieds en bois finitions chromées.

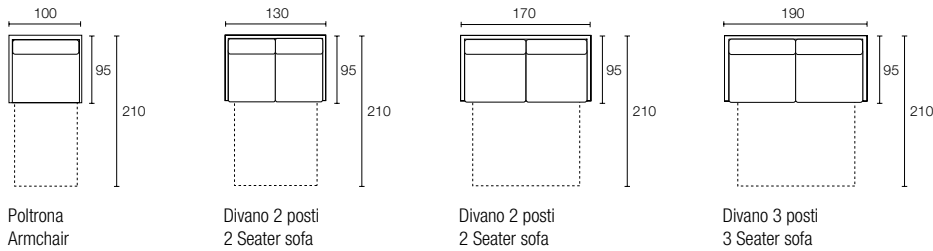

### MERCURIO COLLECTION design> Renato De Lorenzo 2006

Le reti elettrosaldate, inserite in telai di acciaio ad alta resistenza, con cinghie sulla seduta per un maggior comfort, verniciate con polveri epossidiche, sono certificate CATAS. Parti schienale e braccioli in legno massello e multistrato. Completamente assemblabile attraverso un sistema di baionette. Il materasso in poliuretano espanso può essere scelto nella densità, più sostenuto o più elastico, con fodera standard in cotone trapuntato o con tessuto silver dalle caratteristiche antibatteriche, sempre completamente sfoderabili, misure: 100x200 – 140x200 – 160x200. Penisola contenitore con apertura frontale tramite molle a gas Stabilus. Imbottiture in poliuretano ad alta densità oppure poliuretano abbinato a piuma certificata "Assopiuma". Piede legno finiture wengè e cromo. La penisola contenitore è disponibile anche con bracciolo lungo 120 cm, come foto catalogo.

The electrically welded bed base, in a high resistance steel frame, with seat strap for better comfort, and epoxy powder coating, is CATAS certified. Backrest and armrest sections in solid and multilayer wood. Bayonet system for complete assembly. The level of density of the polyurethane foam mattress may be selected by the customer, firmer or softer, with standard padded cotton cover or antibacterial silver material cover, always removable; sizes: 100x200 – 140x200 – 160x200. Stabilus gas spring front opening storage section. High density polyurethane foam padding, or polyurethane combined with "Assopiuma" certified feather. Wooden foot with chrome and wengè finish. The storage section is also available with 120 cm armrest, as shown in the picture in the catalogue.

Les sommiers électrosoudés sont intégrés dans des structures en acier très résistantes, munis de sangles au niveau de l'assise pour plus de confort, peints avec des poudres époxy et certifiés CATAS. Dossier et accoudoirs en bois massif et stratifié. Entièrement assemblable grâce à un système de baïonnette. Vous pouvez choisir un matelas en polyuréthane expansé plus ferme ou plus élastique, avec une housse standard en coton piqué ou un tissu silver antibactérien, le tout entièrement déhoussable. Dimensions: 100x200 – 140x200 – 160x200. Méridienne coffre de rangement avec ouverture à l'avant par ressorts à gaz Stabilus. Garnissage en polyuréthane haute résilience ou mélange de polyuréthane et plumes certifiées "Assopiuma". Pieds en bois finitions wengé et chrome. La méridienne coffre de rangement existe également avec accoudoir de 120 cm de longueur (voir photo du catalogue).

## DIVANI LETTO - SOFA BEDS - CANAPÉS-LITS

### MERCURIO BL



Pag.18-19:  
Divano 3 posti 224 cm.  
3 Seater sofa 224 cm.

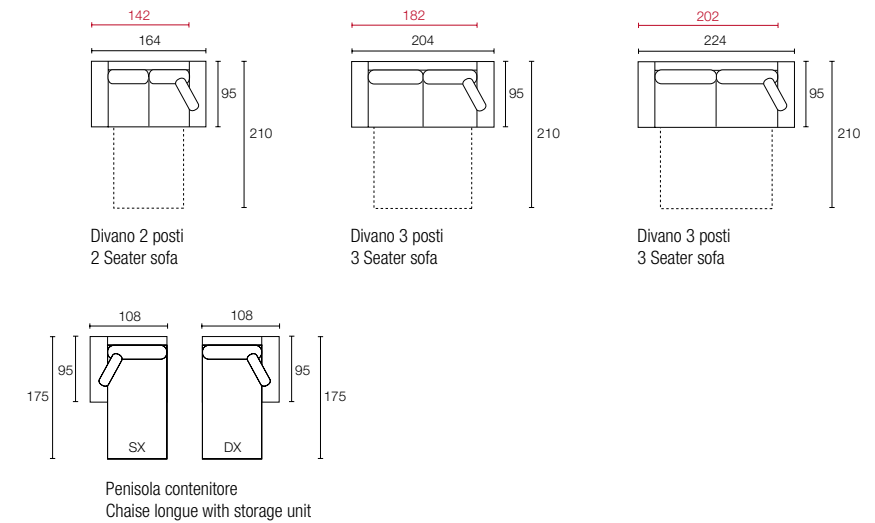

### MERCURIO BS



Pag.32-33:  
Divano 3 posti 200 cm.  
3 Seater sofa 200 cm.

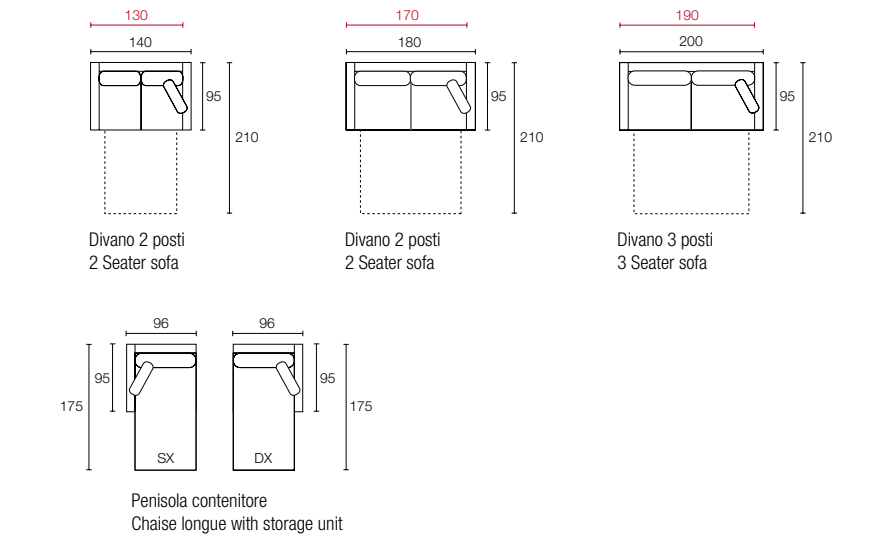

### MERCURIO CLASSICO



Pag.36-37:  
Divano 3 posti 227 cm.  
3 Seater sofa 227 cm.

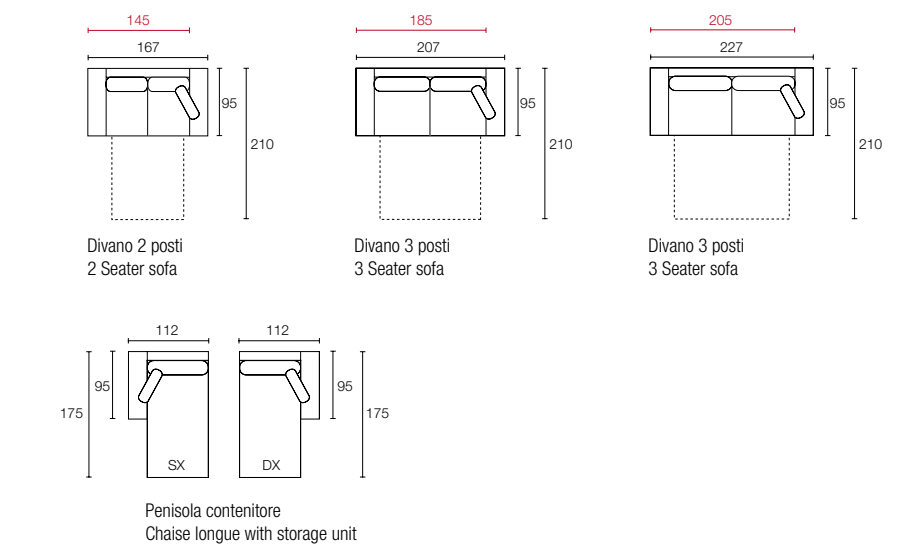

## DIVANI LETTO - SOFA BEDS - CANAPÉS-LITS

**NEXT** design> Renato De Lorenzo 2010



Rete in acciaio tubolare ad alta resistenza con piano letto elettrosaldato, cinghiata nella parte inferiore per un maggior comfort di seduta. Parti schienale e braccioli in legno massello e multistrato. Il materasso in poliuretano espanso può essere scelto nella densità, più sostenuto o più elastico, con fodera standard in cotone trapuntato o con tessuto silver dalle caratteristiche antibatteriche, sempre completamente sfoderabili, misure: 100x200 – 140x200 – 160x200. Imbottiture in poliuretano ad alta densità oppure poliuretano abbinato a piuma certificata "Assopiuma". Penisola contenitore con apertura frontale tramite molle a gas Stabilus. Assemblabile tramite un sistema a baionette. Piede in ferro cromato.

High resistance tubular steel electrically welded bed base, with strapped bottom section for better seating comfort. Backrest and armrest sections in solid and multilayer wood. The level of density of the polyurethane foam mattress may be selected by the customer, firmer or softer, with standard padded cotton cover or antibacterial silver material cover, always removable; sizes: 100x200 – 140x200 – 160x200. High density polyurethane foam padding, or polyurethane combined with "Assopiuma" certified feather. Stabilus gas spring front opening storage section. Bayonet system for complete assembly. Chrome steel foot.

Sommier en acier tubulaire très résistant muni d'une structure de lit électrosoudée et de sangles dans la partie inférieure pour assurer une assise plus confortable. Dossier et accoudoirs en bois massif et stratifié. Vous pouvez choisir un matelas en polyuréthane expansé plus ferme ou plus élastique, avec une housse standard en coton piqué ou un tissu silver antibactérien, le tout entièrement déhoussable. Dimensions: 100x200 – 140x200 – 160x200. Garnissage en polyuréthane haute résilience ou mélange de polyuréthane et plumes certifiées "Assopiuma". Méridienne coffre de rangement avec ouverture à l'avant par ressorts à gaz Stabilus. Assemblable grâce à un système de baionnette. Pieds en fer chromé.

**Pag.12-13:**  
Composizione 317x175 cm.  
Composition 317x175 cm.

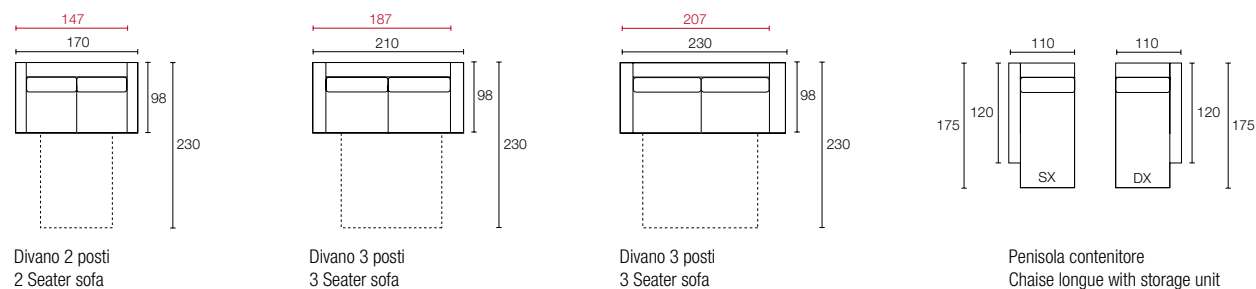

**QUICK** design> Renato De Lorenzo 2011



Materasso unico in poliuretano ad alta densità 80x185 cm. Rete in tubolare d'acciaio, elettrosaldato sul piano letto e cinghiata nella parte inferiore, per un maggior comfort di seduta.

High density polyurethane foam single mattress measuring 80x185 cm. High resistance tubular steel electrically welded bed base, with strapped bottom section for better seating comfort.

Matelas une place en polyuréthane haute résilience 80x185 cm. Sommier en acier tubulaire, électrosoudé au niveau de la structure du lit et muni de sangles dans la partie inférieure pour assurer une assise plus confortable.

**Pag.69:**  
Pouf.

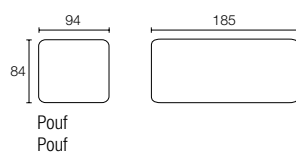

## DIVANI LETTO - SOFA BEDS - CANAPÉS-LITS

**SPACCO** design> Renato De Lorenzo 2004



Materasso in poliuretano espanso ad alta densità è diviso in tre parti da cm 75x195. Rete in acciaio elettrosaldato con piccola testata.

High density polyurethane foam mattress, split in three 75x195 sections. Electrically welded steel bed base with small headboard.

Matelas en polyuréthane expansé haute résilience à trois plis de 75x195. Sommier en acier électrosoudé muni d'une petite tête.

**Pag.70:**  
Pouf.

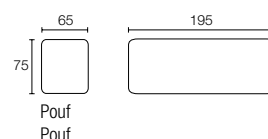

**SUAVE** design> Renato De Lorenzo 2011



Rete in acciaio tubolare ad alta resistenza con piano letto elettrosaldato, cinghiata nella parte inferiore per un maggior comfort di seduta. Il materasso in poliuretano espanso può essere scelto nella densità, più sostenuto o più elastico, con fodera standard in cotone trapuntato o con tessuto silver dalle caratteristiche antibatteriche, sempre completamente sfoderabili, misure: 100x200 – 140x200 – 160x200. La struttura, in legno massello e multistrato, è ricoperta da un'imbottitura in piuma. Sedili e schienali in poliuretano ad alta densità e piuma certificata "Assopiuma". Assemblabile tramite un sistema a baionette. Piede in acciaio satinato.

High resistance tubular steel electrically welded bed base, with strapped bottom section for better seating comfort. The level of density of the polyurethane foam mattress may be selected by the customer, firmer or softer, with standard padded cotton cover or antibacterial silver material cover, always removable; sizes: 100x200 – 140x200 – 160x200. The frame, in solid and multilayer wood, is covered by a feather padding. High density polyurethane foam and "Assopiuma" certified feather seats and backrests. Bayonet system for complete assembly. Satin steel foot.

Sommier en acier tubulaire très résistant muni d'une structure de lit électrosoudée et de sangles dans la partie inférieure pour assurer une assise plus confortable. Vous pouvez choisir un matelas en polyuréthane expansé plus ferme ou plus élastique, avec une housse standard en coton piqué ou un tissu silver antibactérien, le tout entièrement déhoussable. Dimensions: 100x200 – 140x200 – 160x200. La structure, en bois massif et stratifié, est recouverte d'un garnissage en plumes. Assises et dossiers en polyuréthane haute résilience et plumes certifiées "Assopiuma". Assemblable grâce à un système de baionnette. Pieds en acier satiné.

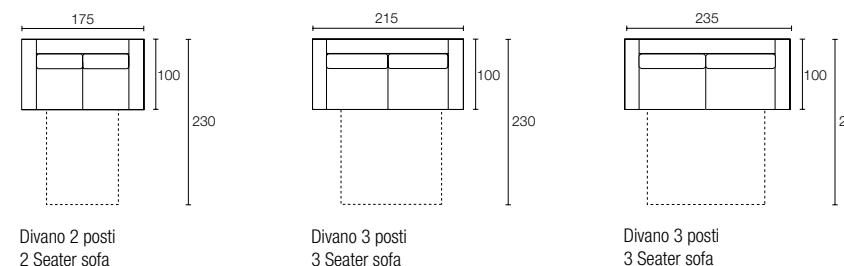

Le misure in rosso sono relative al divano senza un bracciolo, da utilizzare solo per formare la composizione con penisola.  
Measures in red are relative to the sofa without armrest, only for arrangement with chaise longue.  
Mesures en rouge sont pour canapé sans un accoudoir, seulement pour composition avec méridienne.

## LETTI - BEDS - LITS

### ATTORNO design> Renato De Lorenzo 2004



Testata in legno multistrato. Rete in acciaio trafilato con porta doghe inserito. Doghe in legno di faggio, meccanismo a due posizioni. Fondi in bilaminato bordato, spessore 18 mm, maniglie in cuoio per l'estrazione dei pannelli. Finitura del prodotto in tessuto accoppiato.

Multilayer headboard. Drawn steel bed base with slat holder. Beech wood slats, two-position mechanism. Edged double laminate bottoms, 18 mm thick, leather handles for panel extraction. Product finished with coupled fabric.

Tête de lit en bois stratifié. Sommier en acier tréfilé avec porte-lattes intégré. Lattes en bois de hêtre, mécanisme à deux positions. Fonds en bilaminé avec bords, épaisseur 18 mm, poignées en cuir pour l'extraction des panneaux. Finitions textile laminé.

Pag.98-99

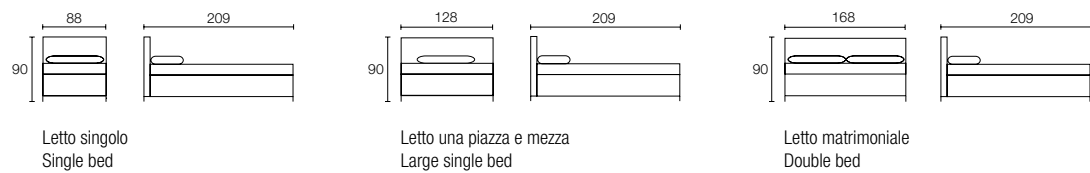

### GEORGE design> Respace studio tecnico 2004



Testata in legno multistrato. Imbottitura dei cuscini in termo legato accoppiato cotone. Rete in acciaio trafilato con porta doghe inserito. Doghe in legno di faggio, meccanismo a due posizioni. Fondi in bilaminato bordato, spessore 18 mm, maniglie in cuoio per l'estrazione dei pannelli. Finitura del prodotto in tessuto accoppiato.

Multilayer headboard. Cushion padding in thermo bonded material coupled with cotton. Drawn steel bed base with slat holder. Beech wood slats, two-position mechanism. Edged double laminate bottoms, 18 mm thick, leather handles for panel extraction. Product finished with coupled fabric.

Tête de lit en bois stratifié. Garnissage des coussins en matière thermoliée mélange coton. Sommier en acier tréfilé avec porte-lattes intégré. Lattes en bois de hêtre, mécanisme à deux positions. Fonds en bilaminé avec bords, épaisseur 18 mm, poignées en cuir pour l'extraction des panneaux. Finitions textile laminé.

Pag.94-95

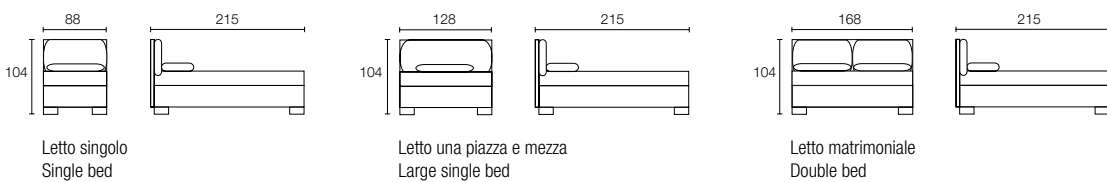

### NIGORA design> Renato De Lorenzo 2006



Testata in legno tamburato. Rete in acciaio trafilato con porta doghe inserito. Doghe in legno di faggio, meccanismo a due posizioni. Fondi in bilaminato bordato, spessore 18 mm, maniglie in cuoio per l'estrazione dei pannelli. Finitura del prodotto in tessuto accoppiato.

Hollow wood headboard. Drawn steel bed base with slat holder. Beech wood slats, two-position mechanism. Edged double laminate bottoms, 18 mm thick, leather handles for panel extraction. Product finished with coupled fabric.

Tête de lit en bois stratifié. Sommier en acier tréfilé avec porte-lattes intégré. Lattes en bois de hêtre, mécanisme à deux positions. Fonds en bilaminé avec bords, épaisseur 18 mm, poignées en cuir pour l'extraction des panneaux. Finitions textile laminé.

Pag.90-91

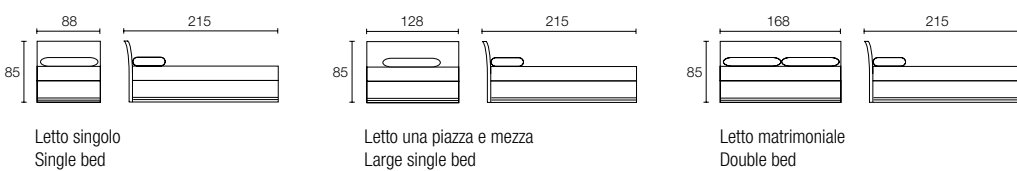

## LETTI - BEDS - LITS

### RI-LETTO design> Renato De Lorenzo 2011



Pag.74-75

Telaio in legno massello e multistrato. Reti con struttura in acciaio ad alta resistenza, sezione tubo 40x30 mm., verniciato a forno con polveri epossidiche. Rete supplementare con testata in acciaio cromato. Snodi pannello in acciaio satinato. Due materassi: sopra 195x85 cm., altezza 15 cm. - sotto 190x80 cm. altezza 15 cm. in poliuretano ad alta densità. Rivestiti con trapuntina in cotone.

Solid and multilayer wood frame. High resistance steel frame bed bases, tube section 40x30 mm., epoxy powder coating. Additional bed base with chrome steel headboard. Panel articulated joints in satin steel. Two mattresses: top 195x85 cm, height 15 cm - bottom 190x80 cm, height 15 mm, high density polyurethane foam. Quilted cotton cover.

Structure en bois massif et stratifié. Sommier avec structure en acier très résistant, section tube: 40x30 mm, peints au four avec poudres époxy. Sommier supplémentaire avec tête en acier chromé. Rotules panneau en acier satiné. Deux matelas: dessus 195x85 cm, hauteur 15 cm - dessous 190x80 cm, hauteur 15 cm, en polyuréthane haute résilience. Revêtement piqué en coton.

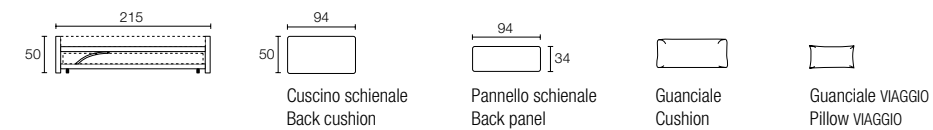

### SLIM design> Respace studio tecnico 2011



Pag.102-103

Imbottitura dei cuscini in termo legato accoppiato cotone. Meccanismo con apertura a compasso. Rete in metallo color alluminio con doghe in legno di faggio, fondo del contenitore in bilaminato grigio metallizzato.

Cushion padding in thermo bonded material coupled with cotton. Compass opening mechanism. Aluminium colour metal bed base with beech wood slats, grey metal finish double laminate container bottom.

Garnissage des coussins en matière thermoliée mélange coton. Mécanisme avec ouverture par compas. Sommier en métal couleur aluminium avec lattes en bois de hêtre, fond du coffre en bilaminé gris métallisé.

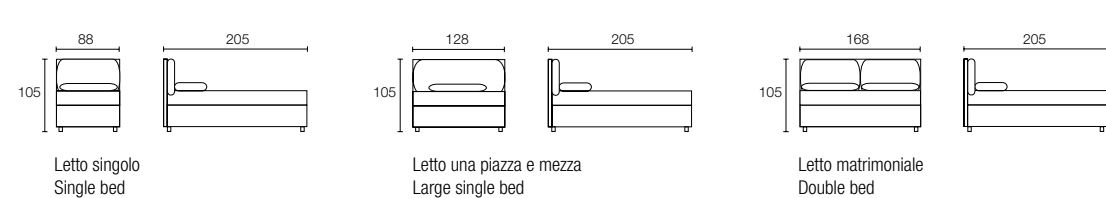

### SOFTLY design> Renato De Lorenzo 2010



Pag.78-79

Testata in legno multistrato. Rete in acciaio trafilato con porta doghe inserito. Doghe in legno di faggio, meccanismo a due posizioni. Fondi in bilaminato bordato, spessore 18 mm, maniglie in cuoio per l'estrazione dei pannelli. Completamente rivestito da un'imbottitura in piuma certificata.

Multilayer headboard. Drawn steel bed base with slat holder. Beech wood slats, two-position mechanism. Edged double laminate bottoms, 18 mm thick, leather handles for panel extraction. Fully covered by certified feather padding.

Tête de lit en bois stratifié. Sommier en acier tréfilé avec porte-lattes intégré. Lattes en bois de hêtre, mécanisme à deux positions. Fonds en bilaminé avec bords, épaisseur 18 mm, poignées en cuir pour l'extraction des panneaux. Entièrement revêtu d'un garnissage en plumes certifiées.

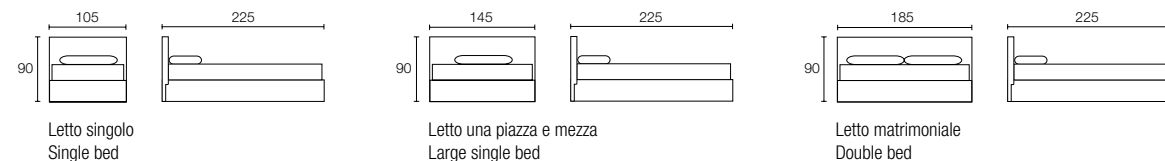

## LETTI - BEDS - LITS

### SOMNUS MAXI design> Renato De Lorenzo 2008



Testata in legno multistrato. Rete in acciaio trafilato con porta doghe inserito. Doghe in legno di faggio, meccanismo a due posizioni. Fondi in bilaminato bordato, spessore 18 mm, maniglie in cuoio per l'estrazione dei pannelli. Giroletto con tamponi ad alta densità SR75. Finitura del prodotto in tessuto accoppiato.

Multilayer headboard. Drawn steel bed base with slat holder. Beech wood slats, two-position mechanism. Edged double laminate bottoms, 18 mm thick, leather handles for panel extraction. SR75 high density pads bed surround. Product finished with coupled fabric.

Tête de lit en bois stratifié. Sommier en acier tréfilé avec porte-lattes intégré. Lattes en bois de hêtre, mécanisme à deux positions. Fonds en bilaminé avec bords, épaisseur 18 mm, poignées en cuir pour l'extraction des panneaux. Tour de lit avec tampons en polyuréthane haute résilience SR75. Finitions textile laminé.

Pag.84-85

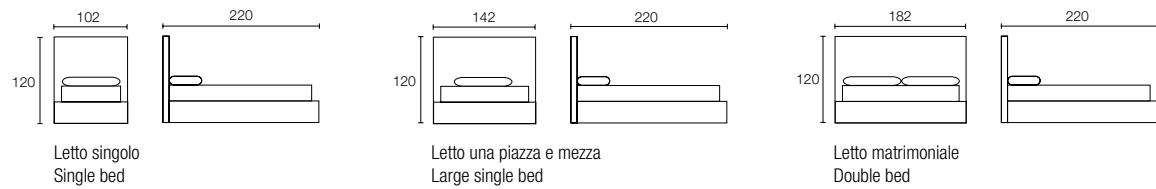

### SOMNUS MIDI design> Renato De Lorenzo 2008



Testata in legno multistrato. Rete in acciaio trafilato con porta doghe inserito. Doghe in legno di faggio, meccanismo a due posizioni. Fondi in bilaminato bordato, spessore 18 mm, maniglie in cuoio per l'estrazione dei pannelli. Giroletto con tamponi ad alta densità SR75. Finitura del prodotto in tessuto accoppiato.

Multilayer headboard. Drawn steel bed base with slat holder. Beech wood slats, two-position mechanism. Edged double laminate bottoms, 18 mm thick, leather handles for panel extraction. SR75 high density pads bed surround. Product finished with coupled fabric.

Tête de lit en bois stratifié. Sommier en acier tréfilé avec porte-lattes intégré. Lattes en bois de hêtre, mécanisme à deux positions. Fonds en bilaminé avec bords, épaisseur 18 mm, poignées en cuir pour l'extraction des panneaux. Tour de lit avec tampons en polyuréthane haute résilience SR75. Finitions textile laminé.

Pag.88-89

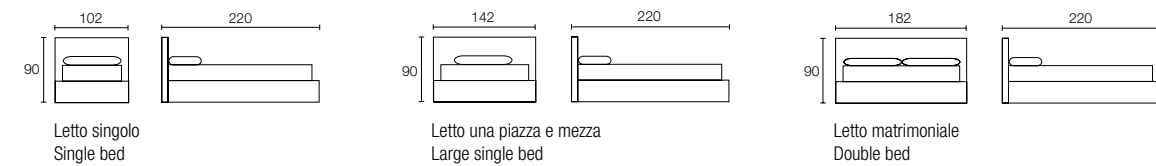

## DIVANI - SOFAS - CANAPÉS

### ELEGANTIA design> Ettore Lariani & Renato De Lorenzo 2008



Telaio in legno massello e multistrato. Molleggio con cinghie elastiche garantito 10 anni. Tamponi in poliuretano SR75. Finitura in tessuto accoppiato. Imbottiture della seduta in poliuretano ad alta densità e memofill, schienali in piumino 20/80 numero indice ossigeno > 20 mg O/100 gr prodotto con trattamento di lavaggio e bonifica igienica. Piede legno finitura wengè o alluminio.

Solid and multilayer wood frame. Elastic strap springing system, guaranteed 10 years. SR75 polyurethane foam pads. Finished with coupled fabric. High density polyurethane foam and memofill padding, 20/80 feather backrests, oxygen index > 20 mg O/100 manufactured using a washing and hygienic decontamination treatment. Wooden foot with wengè or aluminium finish.

Structure en bois massif et stratifié. Ressorts avec sangles élastiques garantis 10 ans. Tampons en polyuréthane SR75. Finitions textile laminé. Garnissage de l'assise en polyuréthane haute résilience et Memofill, dossiers en plumes 20/80 indice d'oxygène > 20 mg O/100 g produit ayant été soumis à nettoyage et assainissement hygiénique. Pieds en bois finitions wengé ou aluminium.

Pag.124-125:

Divano completo 4 posti 300 cm.  
4 Seater sofa with pillows 300 cm.

#### ELEMENTI PROFONDITA' 100 - ELEMENTS WITH DEPTH 100

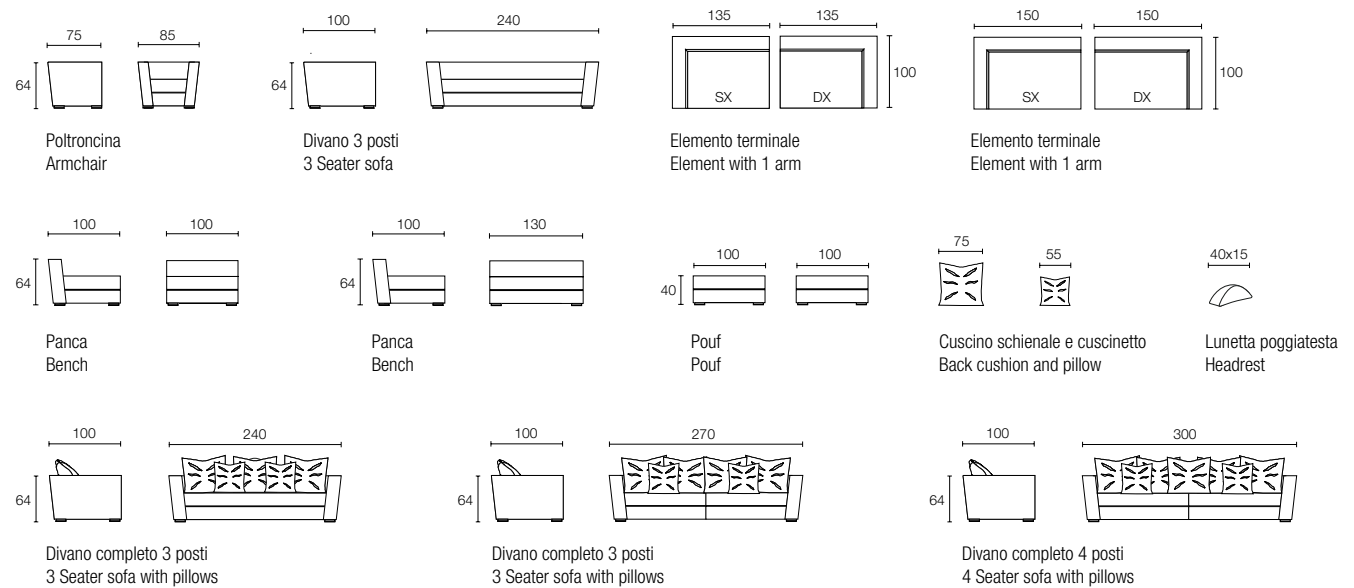

#### ELEMENTI PROFONDITA' 120 - ELEMENTS WITH DEPTH 120

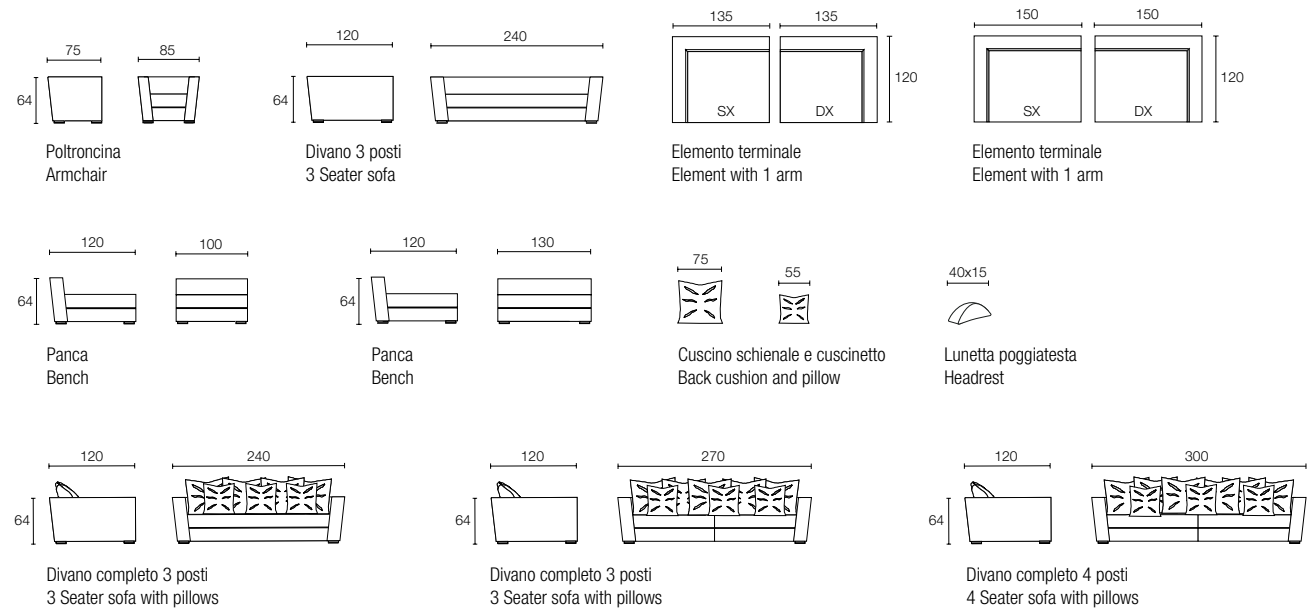

## DIVANI - SOFAS - CANAPÉS

### LEONARD design> Respace studio tecnico 2007



Telaio in legno massello e multistrato. Molleggio con cinghie elastiche garantito 10 anni. Tamponi in poliuretano SR75. Finitura in tessuto accoppiato. Imbottiture della seduta in poliuretano ad alta densità e piuma, schienali in piuma certificata "Assopiuma". Piedi antiscivolo e basamento in ferro cromato.

Solid and multilayer wood frame. Elastic strap springing system, guaranteed 10 years. SR75 polyurethane foam pads. Finished with coupled fabric. High density polyurethane foam and feather padded seat, "Assopiuma" certified feather backrest. Non-slip foot and chrome steel base.

Structure en bois massif et stratifié. Ressorts avec sangles élastiques garantis 10 ans. Tampons en polyuréthane SR75. Finitions textile laminé. Garnissage de l'assise en polyuréthane haute résilience et Memofill, dossiers en plumes certifiées "Assopiuma". Pieds antidérapants et piètement en fer chromé.

#### Pag.116-117:

2 el. 150 cm + 1 panca 130 cm + 1 pouf 100 cm.  
2 el. 150 cm + 1 bench 130 cm + 1 pouf 100 cm.

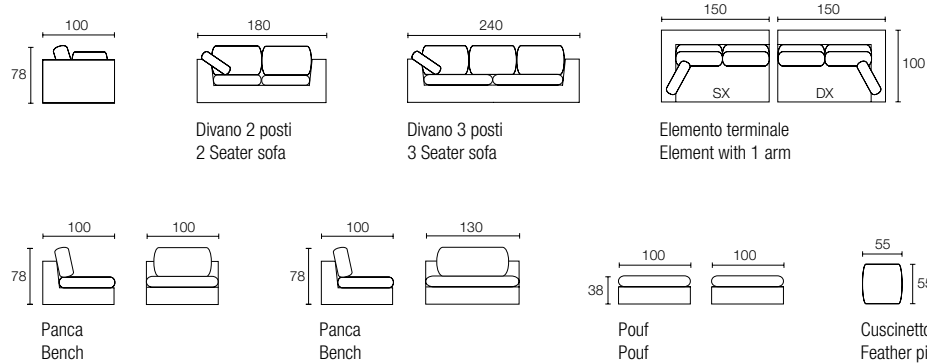

### MOTUS design> Respace studio tecnico 2009



Telaio in legno massello e multistrato. Molleggio con cinghie elastiche garantito 10 anni. Tamponi in poliuretano SR75. Finitura in tessuto accoppiato. Imbottiture in poliuretano ad alta densità. Meccanismo in acciaio con pistone idraulico e cricchetti posizionabili.

Solid and multilayer wood frame. Elastic strap springing system, guaranteed 10 years. SR75 polyurethane foam pads. Finished with coupled fabric. High density polyurethane foam padding. Steel mechanism with hydraulic piston and adjustable ratchet handles.

Structure en bois massif et stratifié. Ressorts avec sangles élastiques garantis 10 ans. Tampons en polyuréthane SR75. Finitions textile laminé. Garnissage en polyuréthane haute résilience. Mécanisme en acier avec piston hydraulique et cliquets positionnables.

#### Pag.132-133:

Divano 3 posti 200 cm.  
3 Seater sofa 200 cm.

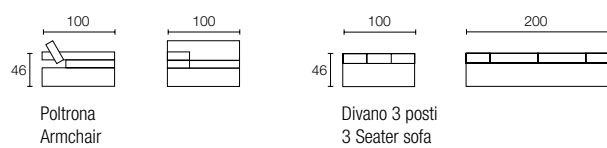

## DIVANI - SOFAS - CANAPÉS

### PLANET design> Respace studio tecnico 2011



Telaio in legno massello e multistrato. Molleggio con cinghie elastiche garantito 10 anni. Tamponi in poliuretano SR75. Finitura in tessuto accoppiato. Imbottiture della seduta in poliuretano ad alta densità ecolast 40 oppure con inserto in ecolast 50 e piuma. Schienali e cuscini in piuma certificata "Assopiuma" etichetta ORO. Piede in acciaio satinato.

Solid and multilayer wood frame. Elastic strap springing system, guaranteed 10 years. SR75 polyurethane foam pads. Finished with coupled fabric. High density ecolast 40 polyurethane foam, or ecolast insert 50 and feather seat padding. Backrests and cushions in "Assopiuma" certified feather with ORO label. Satin steel foot.

Structure en bois massif et stratifié. Ressorts avec sangles élastiques garantis 10 ans. Tampons en polyuréthane SR75. Finitions textile laminé. Garnissage de l'assise en polyuréthane haute résilience Ecoelast 40 ou avec garnissage Ecoelast 50 et plumes. Dossiers et coussins en plumes certifiées "Assopiuma" étiquette d'or. Pieds en acier satiné.

#### Pag.108-109:

3 el. 100x97 cm + 2 braccioli 97 cm + 1 pouf 97 cm.  
3 el. 100x97 cm + 2 arms 97 cm + 1 pouf 97 cm.

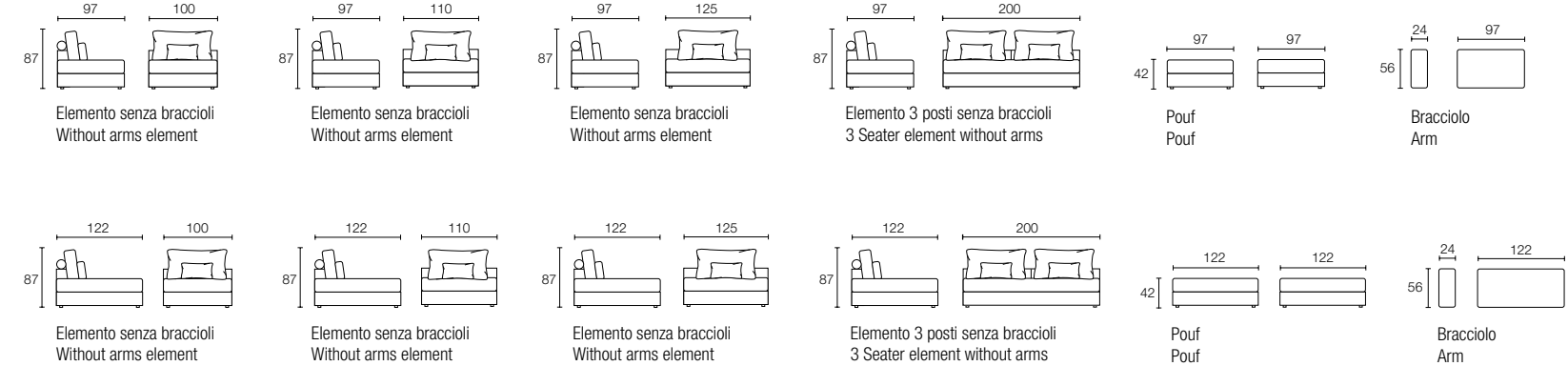

### ROGER design> Respace studio tecnico 2006



Telaio in legno massello e multistrato. Molleggio con cinghie elastiche garantito 10 anni. Tamponi in poliuretano SR75. Finitura in tessuto accoppiato. Imbottiture della seduta in poliuretano ad alta densità, schienali in piuma certificata "Assopiuma". Piede in legno finitura cromo.

Solid and multilayer wood frame. Elastic strap springing system, guaranteed 10 years. SR75 polyurethane foam pads. Finished with coupled fabric. High density polyurethane foam padded seat, "Assopiuma" certified feather backrest. Wooden foot with chrome finish.

Structure en bois massif et stratifié. Ressorts avec sangles élastiques garantis 10 ans. Tampons en polyuréthane SR75. Finitions textile laminé. Garnissage de l'assise en polyuréthane haute résilience et Memofill, dossiers en plumes certifiées "Assopiuma". Pied en bois finitions chrome.

#### Pag.136-137:

2 el. terminali 150 cm + 1 panca 130 cm.  
2 el. with 1 arm 150 cm + 1 bench 130 cm.

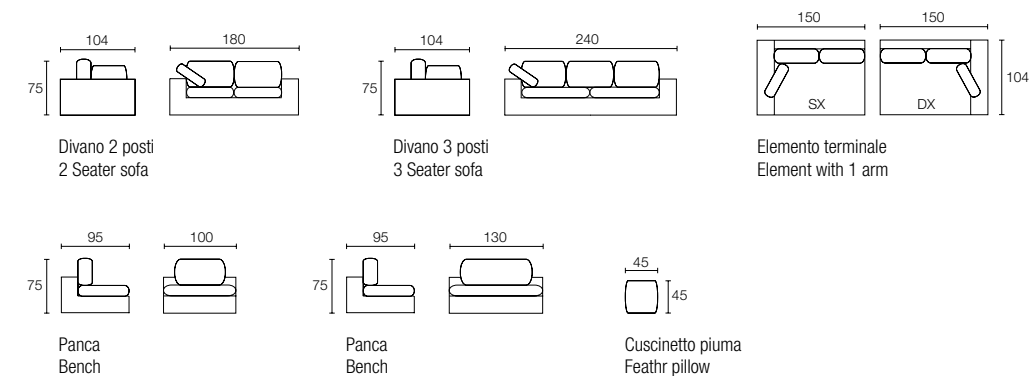



## SEDUTE - SEATS - CHAISE

### PLAYSPACE design> Respace studio tecnico 2007



Composto da una sacca interna contenente microsfere in polistirene miste a espanso a Memoria di forma. Interamente sfoderabile. PLAYSPACE è ricaricabile: nell'uso prolungato e intensivo potrebbe verificarsi un decadimento dell'originario volume della sacca interna. Respace fornisce le ricariche da integrare con l'imbottitura già presente all'interno. Materiali e produzione interamente Made in Italy.

PLAYSPACE consists of an internal bag containing polystyrene and memory foam micro-balls with an easy-to-remove cover. It is refillable: the original volume of the internal bag can decrease the longer and more intensively it is used. Respace provides refills which can be added to the padding inside. Materials and manufacture all in Italy.

PLAYSPACE est composé d'une poche interne contenant des microsphères en polystyrène et expansé à mémoire de forme et est entièrement déhoussable. Il est rechargeable. En effet, à long terme, après une usage intensif, il se peut que le volume original de la poche interne diminue. Respace fournit les recharges déjà munies du garnissage. Tous les matériaux et la production sont Made in Italy.

Pag.142-143

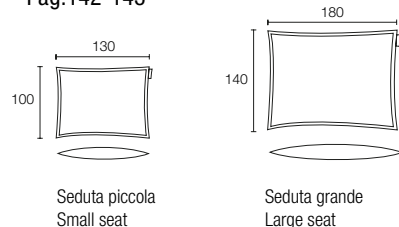

Seduta piccola  
Small seat

Seduta grande  
Large seat

### Q-BELLO design> Respace studio tecnico 2007



Pouf a memoria di forma, comodo e pratico sia per abitazioni che per locali pubblici e Spa.

A pouf made of memory foam comfortable and practical for the home, communal areas and Spas.

Pouf à mémoire de forme, confortable et pratique aussi bien pour les habitations que pour les lieux publics et les Spas.

Pag.152-153

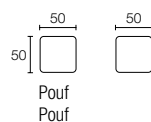

Pouf  
Pouf

### RINGSPACE design> Respace studio tecnico 2011



Spazio rotondo, per sedersi in 1, 2 anche 3, da usare come appoggio o come gioco, simpatico oggetto adatto ad ogni ambiente. Imbottitura protetta da una sacca interna contenente microsfere di polistirene. Interamente sfoderabile.

A round space for seating 1, 2 or even 3 people, to be used as a support or for play; a fun object suited to all environments. Padding protected by an internal bag containing polystyrene micro-balls. Removable cover.

Modèle rond pour s'asseoir seul, à deux ou à trois, à utiliser comme support ou pour s'amuser. Objet sympathique idéal pour tous les environnements. Garnissage protégé par une poche interne contenant des microsphères en polystyrène. Entièrement déhoussable.

Pag.148-149

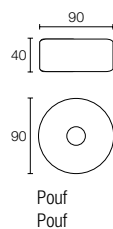

Pouf  
Pouf

## OPTIONAL

### MATERASSO E FODERA - MATTRESS AND COVER - MATELAS ET HOUSSES



MATERASSO PER I MODELLI - MATTRESS FOR MODELS - MATELAS POUR LES DIFFÉRENTS MODÈLES:  
Joint, Logic, Mercurio, Next, Suave.

É possible richiedere il materasso in poliuretano espanso con una densità maggiore rispetto a quella standard, sempre nelle misure: 100x200 – 140x200 – 160x200.

É inoltre possibile avere la fodera Silver con proprietà antibatteriche ed antistatiche, in sostituzione a quella standard.

Polyurethane foam mattresses with higher density than the standard density available on requests, in the following sizes: 100x200 cm – 140x200 cm – 160x200 cm.

Silver cover with antibacterial and antistatic properties also available on request as a replacement of the standard cover.

Il est possible de demander un matelas en polyuréthane expansé dont la densité est supérieure à la densité standard, dimensions: 100 x 200 – 140 x 200 – 160 x 200.

En outre, il est possible de remplacer la housse standard par la housse Silver, aux propriétés antibactériennes et antistatiques.

### RUOTA - WHEEL - ROULETTES



RUOTA PER I MODELLI - WHEEL FOR MODELS - ROULETTES POUR LES DIFFÉRENTS MODÈLES:  
Attorno, George, Nigora, Slim, Softly, Somnus, Logic, Mercurio BS, Mercurio Classico.

Ruota con freno per il blocco del divano o del letto. Colori disponibili: nero+alluminio e arancio+ bianco.

Wheel with brake for keeping the sofa or bed in place. Colours available: black+aluminium and orange+white.

Roulettes avec frein pour bloquer le canapé ou le lit. Couleurs disponibles: noir+aluminium et orange+blanc.

SI GARANTISCE CHE TUTTA LA PRODUZIONE RESPACE È REALIZZATA IN ITALIA.  
WE GUARANTEE THAT ALL RESPACE PRODUCTION IS REALISED EXCLUSIVELY IN ITALY.  
ON GARANTI QUE TOUT LA PRODUCTION DE RESAPCE EST REALISÉÉ EXCLUSIVEMENT EN ITALY.

Le illustrazioni hanno solo valore indicativo. Respace si riserva il diritto di apportare tutti gli accorgimenti estetico-costruttivi che riterrà utili a migliorare il prodotto.  
La proprietà, la realizzazione e riproduzione delle caratteristiche estetiche e costruttive qui illustrate sono riservate a termini di legge.  
I colori hanno valore indicativo in quanto soggetti alle tolleranze dei processi di stampa.

These pictures have only an approximate value. Respace reserves the right to make any useful change to improve its products.  
The property, the realization and the reproduction of the aesthetic and constructive characteristics, here illustrated, are reserved by law.  
Colours are indicative as they are subject to the alterations of the printing process.

Ces illustrations sont seulement indicatives. L'usine Respace a le droit de changer son produit, d'un point de vue esthétique ou de construction, afin de l'améliorer.  
La propriété, la réalisation et la reproduction des caractéristiques esthétiques et de construction ci-illustrées sont réservées selon la loi.  
Les coloris sont seulement indicatifs dès qu'ils peuvent subir des modifications de ton pendant le processus d'imprimerie.

**REspace srl**

20843 Verano Brianza (MB) Italia

S.S. 36 Km 23.50

Tel +39 0362-803716 - Fax +39 0362-1792707

[www.respace.it](http://www.respace.it) - [info@respace-srl.it](mailto:info@respace-srl.it)